

Архангельск (8182)63-90-72
 Астана (7172)727-132
 Астрахань (8512)99-46-04
 Барнаул (3852)73-04-60
 Белгород (4722)40-23-64
 Брянск (4832)59-03-52
 Владивосток (423)249-28-31
 Волгоград (844)278-03-48
 Вологда (8172)26-41-59
 Воронеж (473)204-51-73
 Екатеринбург (343)384-55-89
 Иваново (4932)77-34-06

Ижевск (3412)26-03-58
 Иркутск (395)279-98-46
 Казань (843)206-01-48
 Калининград (4012)72-03-81
 Калуга (4842)92-23-67
 Кемерово (3842)65-04-62
 Киров (8332)68-02-04
 Краснодар (861)203-40-90
 Красноярск (391)204-63-61
 Курск (4712)77-13-04
 Липецк (4742)52-20-81
 Киргизия (996)312-96-26-47

Магнитогорск (3519)55-03-13
 Москва (495)268-04-70
 Мурманск (8152)59-64-93
 Набережные Челны (8552)20-53-41
 Нижний Новгород (831)429-08-12
 Новокузнецк (3843)20-46-81
 Новосибирск (383)227-86-73
 Омск (3812)21-46-40
 Орел (4862)44-53-42
 Оренбург (3532)37-68-04
 Пенза (8412)22-31-16
 Казахстан (772)734-952-31

Пермь (342)205-81-47
 Ростов-на-Дону (863)308-18-15
 Рязань (4912)46-61-64
 Самара (846)206-03-16
 Санкт-Петербург (812)309-46-40
 Саратов (845)249-38-78
 Севастополь (8692)22-31-93
 Симферополь (3652)67-13-56
 Смоленск (4812)29-41-54
 Сочи (862)225-72-31
 Ставрополь (8652)20-65-13
 Россия (495)268-04-70

Сургут (3462)77-98-35
 Тверь (4822)63-31-35
 Томск (3822)98-41-53
 Тула (4872)74-02-29
 Тюмень (3452)66-21-18
 Ульяновск (8422)24-23-59
 Уфа (347)229-48-12
 Хабаровск (4212)92-98-04
 Челябинск (351)202-03-61
 Череповец (8202)49-02-64
 Ярославль (4852)69-52-93

<https://ebro-armaturen.nt-rt.ru/> || ero@nt-rt.ru

ЗАТВОР С ЦЕНТРАЛЬНЫМ ФЛАНЦЕМ М 015-А

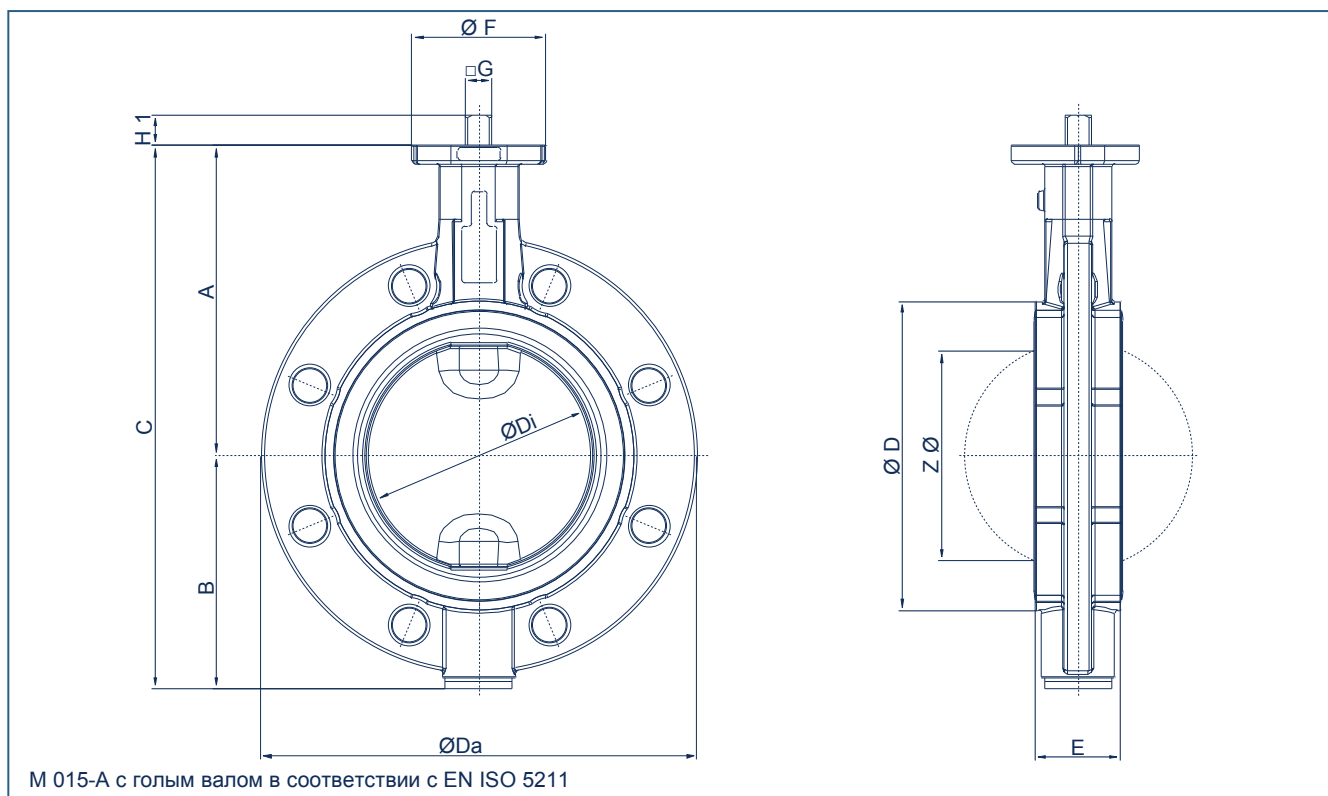

DN [мм]	Размер [Дюйм]	Основные размеры [мм]													Состав вал	TS- вал
		A	B	C	D	Di	Da		E	F	Фланец	G	H1	Z		
80	3	157	105	262	128	79	200	200	46	65	F05	14	17	64	4,7	-
100	4	168	115	282	145	99	220	220	52	65	F05	14	17	84	5,8	-
125	5	180	127	307	180	124	250	250	56	65	F05	14	17	110	7,8	-
150	6	203	152	355	202	148	285	285	56	88	F07	17	20	137	10,9	11,4
200	8	229	178	406	250	199	340	340	60	88	F07	17	20	189	14,8	15,9
250	10	266	213	479	314	248	395	405	68	125	F10	22	24	239	26,0	29,4
300	12	291	238	529	360	297	445	460	78	125	F10	22	24	287	34,2	37,3
350	14	332	270	602	415	338	505	520	78	150	F12	27	29	328	50,5	56,5
400	16	363	314	677	470	390	565	580	102	150	F12	27	29	376	68,0	75,3

Возможны технические изменения без предварительного уведомления

ЗАТВОР С ЦЕНТРАЛЬНЫМ ФЛАНЦЕМ М 015-А

Спецификация материалов и запасных частей

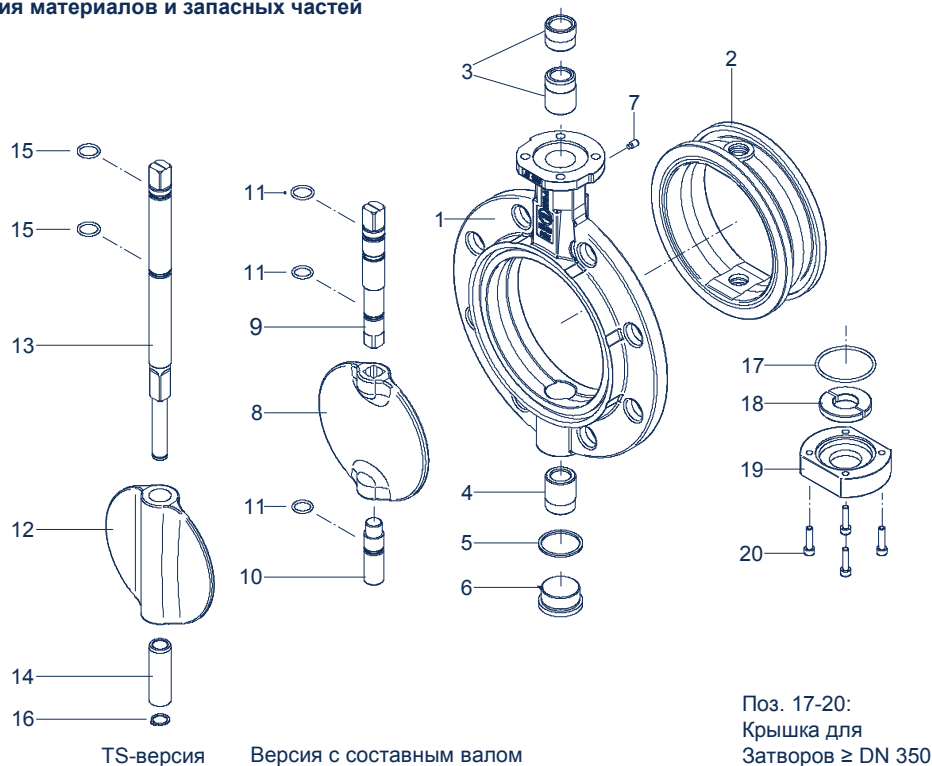

Pt.	Description	Material	Material-No.	ASTM	Pt.	Description	Material	Material-No.	ASTM
1	Body				11	O-ring			
	Grey Cast Iron	GGG-40	0.7040	60-40-18		NBR	Nitrile butadiene rubber		
2	Seat					FPM	Fluorocarbon rubber		
	NBR	Nitrile butadiene rubber			12	TS-disc			
	EPDM	Ethylene propylene diene monomer rubber				Nodular Cast Iron	GGG-40	0.7040	60-40-18
	CSM	Chlorosulfonated polyethylene rubber				Stainless Steel	G-X5CrNiMo19-11-2	1.4408	CF8M
	FPM	Fluorocarbon rubber				Aluminium Bronze	G-CuAl10Ni	2.0975	C 95800
	VSI	Silicon rubber				Coating	Halar, Rilsan		
	SBR-green	Styrene butadiene rubber				Surface quality	electropolished, mirror finished		
3/4	Bearing bush				13	TS-shaft			
	Brass	MS 58	2.0401	B 45		Stainless Steel	X14CrMoS17	1.4104	430 F
	Polyamide	PA 66					X39CrMo17-1	1.4122	
	PTFE	Polytetrafluorethylene					X5CrNiMo17-12-2	1.4401	316
5	Seal DIN 7603					Aluminum Bronze	CuAl10Ni	2.0975	
	Copper	Cu		Copper	14	Sleeve			
6	Plug screw DIN 908					Stainless Steel	X5CrNi18-10	1.4301	304
	Stainless Steel	G-X5CrNiMo19-11-2	1.4408	CF8M	15	O-ring			
7	Set screw DIN 915					NBR	Nitrile butadiene rubber		
	Steel	45 H galvanized				FPM	Fluorocarbon rubber		
	Stainless Steel	A4-70		B8M	16	Retaining ring			
8	Disc					Stainless Steel	X39CrMo17-1	1.4122	
	Steel	St 52.3	1.0570	572-50	17	O-ring			
	Stainless Steel	G-X5CrNiMo19-11-2	1.4301	304		NBR	Nitrile butadiene rubber		
		G-X6CrNiMo18-10	1.4408	CF8M	18	Shaft retainer			
		X2CrNiMo17-12-2	1.4404	316 L		Brass	MS 58	2.0401	B 45
		X6CrNiMoTi17-12-2	1.4571	316 Ti	19	Cover plate			
		X2CrNiMoN22-5-3	1.4469	F 51		Grey Cast Iron	GG-25	0.6025	40 B
		Hastelloy	2.4883	Hastelloy	20	Screw			
	Aluminium Bronze	G-CuAl10Ni	2.0975	C 95800		Steel	45 H galvanized		
	Coating	Halar, Rilsan, NBR, EPDM				Stainless Steel	A2-70		B 8
	Surface quality	electropolished, mirror finished					A4-70		B8M
9/10	Shafts								
	Stainless Steel	X39CrMo17-1	1.4122						
		X14CrMoS17	1.4104	430 F					
		X5/(X2)CrNiMo17-12-2	1.4401/1.4404	316					
		Hastelloy	2.4883	Hastelloy					
	Aluminum Bronze	CuAl10Ni	2.0975						
									Other materials upon request

Возможны технические изменения без предварительного уведомления

CENTRE FLANGED BUTTERFLY VALVE TYPE M 015-A

TORQUE

- The values listed in the table are initial breakaway torques, taken with liquids and lubricant media.

- Please regard these as approximate values, as the objective value depends on different factors like pressure, medium, rubber, quality, temperature ... etc.

- Our engineers look forward to help you with exact values for your application.

- Powdery (non-lubricant) media
Md x 1,3

- Dry gases/high viscous media
Md x 1,2

DN [mm]	Size [in]	Adapted Disc Size Pressure Rating			
		3 bar disc	6 bar disc	10 bar disc	16 bar disc
80	3	8	10	18	24
100	4	9	18	28	37
125	5	15	22	45	59
150	6	36	45	78	125
200	8	59	76	140	200
250	10	150	180	200	240
300	12	200	240	280	360
350	14	350	540	610	700
400	16	420	620	750	850

All values in Nm

K_v-VALUES

- The K_v-values [m³ per hour] is the flow of water at a temperature of 5°C to 30°C (41°F to 86°F) at Δp of 1 bar

- The K_v-values specified are based on tests carried out by the Delfter Hydraulics Laboratories, the Netherlands

- Permissible velocity of flow
V_{max} 4,5 m/s for liquids,
V_{max} 70 m/s for gases

- The throttle function is linear at an angle 30° to 70°

- Avoid cavitation

For further values, please contact our engineers.

DN [mm]	Size [in]	Opening angle α°							
		20°	30°	40°	50°	60°	70°	80°	90°
80	3	15,6	20,6	51,4	102	165	234	304	368
100	4	24,9	39,8	96,5	183	288	398	503	589
125	5	51,8	67,2	135	256	428	652	926	1250
150	6	76,5	97,3	197	375	629	957	1360	1830
200	8	137	187	373	697	1160	1760	2510	3400
250	10	227	271	563	1090	1850	2830	4010	5390
300	12	287	409	820	1550	2610	4050	5880	8120
350	14	399	488	1070	2110	3590	5480	7760	10400
400	16	557	703	1360	2600	4470	7060	10400	14600

Subject to change without notice

Архангельск (8182)63-90-72
Астана (7172)727-132
Астрахань (8512)99-46-04
Барнаул (3852)73-04-60
Белгород (4722)40-23-64
Брянск (4832)59-03-52
Владивосток (423)249-28-31
Волгоград (844)278-03-48
Вологда (8172)26-41-59
Воронеж (473)204-51-73
Екатеринбург (343)384-55-89
Иваново (4932)77-34-06

Ижевск (3412)26-03-58
Иркутск (395)279-98-46
Казань (843)206-01-48
Калининград (4012)72-03-81
Калуга (4842)92-23-67
Кемерово (3842)65-04-62
Киров (8332)68-02-04
Краснодар (861)203-40-90
Красноярск (391)204-63-61
Курск (4712)77-13-04
Липецк (4742)52-20-81
Киргизия (996)312-96-26-47

Магнитогорск (3519)55-03-13
Москва (495)268-04-70
Мурманск (8152)59-64-93
Набережные Челны (8552)20-53-41
Нижний Новгород (831)429-08-12
Новокузнецк (3843)20-46-81
Новосибирск (383)227-86-73
Омск (3812)21-46-40
Орел (4862)44-53-42
Оренбург (3532)37-68-04
Пенза (8412)22-31-16
Казахстан (772)734-952-31

Пермь (342)205-81-47
Ростов-на-Дону (863)308-18-15
Рязань (4912)46-61-64
Самара (846)206-03-16
Санкт-Петербург (812)309-46-40
Саратов (845)249-38-78
Севастополь (8692)22-31-93
Симферополь (3652)67-13-56
Смоленск (4812)29-41-54
Сочи (862)225-72-31
Ставрополь (8652)20-65-13
Россия (495)268-04-70

Сургут (3462)77-98-35
Тверь (4822)63-31-35
Томск (3822)98-41-53
Тула (4872)74-02-29
Тюмень (3452)66-21-18
Ульяновск (8422)24-23-59
Уфа (347)229-48-12
Хабаровск (4212)92-98-04
Челябинск (351)202-03-61
Череповец (8202)49-02-64
Ярославль (4852)69-52-93