

Архангельск (8182)63-90-72
Астана (7172)727-132
Астрахань (8512)99-46-04
Барнаул (3852)73-04-60
Белгород (4722)40-23-64
Брянск (4832)59-03-52
Владивосток (423)249-28-31
Волгоград (844)278-03-48
Вологда (8172)26-41-59
Воронеж (473)204-51-73
Екатеринбург (343)384-55-89
Иваново (4932)77-34-06

Ижевск (3412)26-03-58
Иркутск (395)279-98-46
Казань (843)206-01-48
Калининград (4012)72-03-81
Калуга (4842)92-23-67
Кемерово (3842)65-04-62
Киров (8332)68-02-04
Краснодар (861)203-40-90
Красноярск (391)204-63-61
Курск (4712)77-13-04
Липецк (4742)52-20-81
Киргизия (996)312-96-26-47

Магнитогорск (3519)55-03-13
Москва (495)268-04-70
Мурманск (8152)59-64-93
Набережные Челны (8552)20-53-41
Нижний Новгород (831)429-08-12
Новокузнецк (3843)20-46-81
Новосибирск (383)227-86-73
Омск (3812)21-46-40
Орел (4862)44-53-42
Оренбург (3532)37-68-04
Пенза (8412)22-31-16
Казахстан (772)734-952-31

Пермь (342)205-81-47
Ростов-на-Дону (863)308-18-15
Рязань (4912)46-61-64
Самара (846)206-03-16
Санкт-Петербург (812)309-46-40
Саратов (845)249-38-78
Севастополь (8692)22-31-93
Симферополь (3652)67-13-56
Смоленск (4812)29-41-54
Сочи (862)225-72-31
Ставрополь (8652)20-65-13
Россия (495)268-04-70

Сургут (3462)77-98-35
Тверь (4822)63-31-35
Томск (3822)98-41-53
Тула (4872)74-02-29
Тюмень (3452)66-21-18
Ульяновск (8422)24-23-59
Уфа (347)229-48-12
Хабаровск (4212)92-98-04
Челябинск (351)202-03-61
Череповец (8202)49-02-64
Ярославль (4852)69-52-93

<https://ebro-armaturen.nt-rt.ru/> || ero@nt-rt.ru

Knife gate valve WB14E

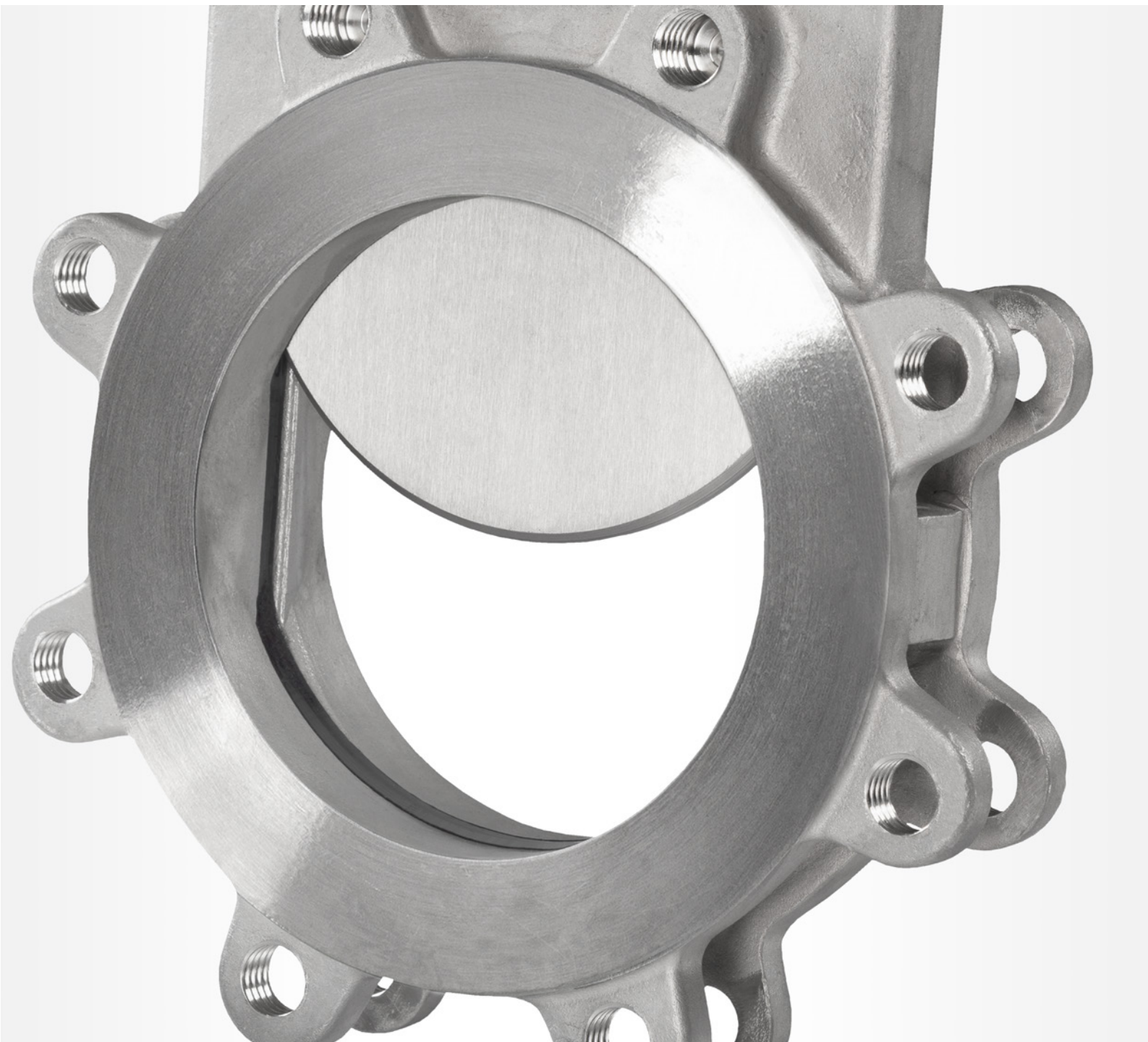

Knife gate valve WB14E

Stafsjö's WB14E knife gate valve is a high performance shut-off valve with superior flow characteristics, offering bi-directional zero leakage shut-off up to 150 psi/10 bar. It is suitable for media such as pulp stock, chemicals, sludge, bio mass, slurry and water. The fully lugged body design is suitable for dead-end services.

The WB14E is supplied with stainless steel wetted parts including the fully lugged valve body, highly polished gate and gland. Up to DN 300 it holds a one piece valve body and from DN 350 it features a rigid two piece version. Staffsjö's gland box system with TwinPack braids and extra PTFE scrapers ensures that no media reaches the surrounding environment. A smooth cycling and a tight shut-off independent of valve position is achieved by the high strength top works that provide an essential alignment for the gate. It utilizes stainless steel tie rods encapsulated inside the structural beams.

Staffsjö's fully modular concept is also applied on the WB14E which makes it easy to equip with manual as well as automatic actuators and related automation accessories. The valve is also available with mechanical lock out.

The WB14E meets the requirements of MSS SP-81, and is designed, manufactured, inspected and tested according to pressure equipment directive 2014/68/EU category I and II module A2. The valve is CE marked when it is applicable.

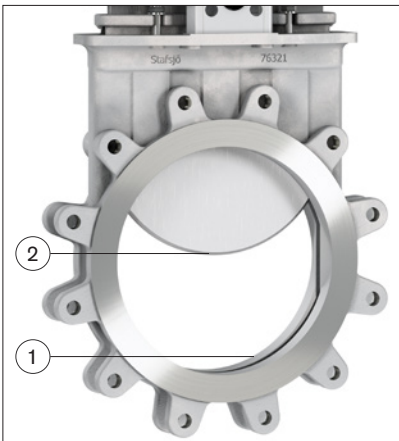

Full bore with superior flow characteristics

The cavity free bore (1) prevent any build up of media during operation.

The highly polished gate (2) with the dual bevel edge and reduced gate profile make it easy for the gate to cut through the media. The design also prevents media from wedging between the gate and body as the valve closes.

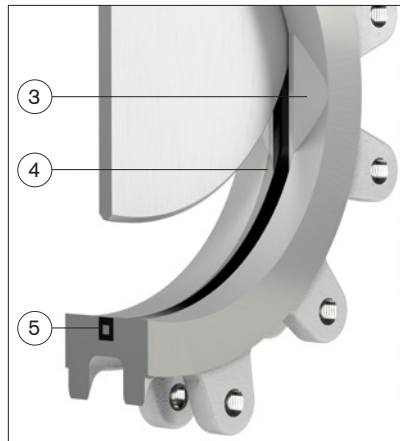

Bi-directional zero leakage shut-off

Gate guides (3) support the gate through the entire range of travel. In bottom of the guides, the relief areas (4) promote a self-cleaning, flushing action as the gate moves into the final stage of closure.

The perimeter resilient seat provides tight shut-off in both directions. The seat is also reinforced with a stainless steel core (5) to enhance durability.

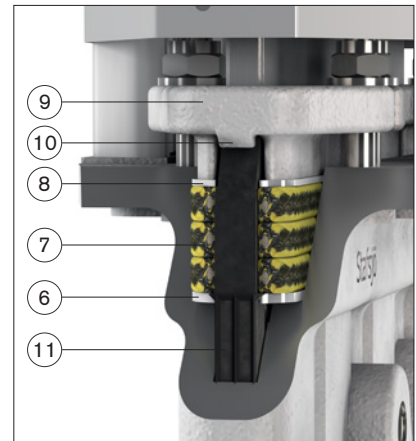

A first rate external sealing

The box bottom scraper (6) scrapes the gate clean, while Staffsjö's TwinPack (7) perform the main sealing function. An optional top scraper (8) fully encapsulate the gland box system and the gland (9) ensure an even distribution. The gland also features linear locks (10) up to DN 300 that securely hold the seat in position as the gate strokes. From DN 350 the seat is locked between the valve body halves.

The flexible profile (11) on the outside surface of the seat up to DN 300 energizes sealing while reducing friction and providing longer cycle life.

Design data

Sizes	Flange drilling	Face-to-face-dimension	ATEX design
DN 80 - DN 600	ASME/ANSI B 16.5 Class 150 EN 1092 PN10 AS 2129 Table D and E	MSS-SP81	On request directive 2014/34/EU Group II category: 3 G/D (zone 2 or 22) 2 G/D (zone 1 or 21)

Other sizes and flange drillings on request.

Leakage rate	Pressure tests
EN 12266-1:2009 rate A: No visually detectable leakage is allowed for duration of the test.	Pressure tests are performed with water at 20° C according to EN 12266-1:2009. Pressure shell test: 1,5 times maximum allowable working pressure for open valve. Pressure seat tightness test: 1,1 times maximum allowable differential pressure for closed valve.

Maximum working pressure body at 20°C		Maximum differential pressure at 20°C	
DN	bar	DN	bar
80 - 600	10	80 - 300	10
		350 - 450	6 or 10
		500 - 600	4 or 10

Basic equipment

A. Valve Body			
Material	Code	Type	Maximum temperature °C
Stainless steel	E	EN 1.4408	400

B. Gate	
Material	Type
Stainless steel	EN 1.4404 (AISI 316L)
Duplex stainless steel ¹⁾	EN 1.4462 (S32205)

¹⁾ Standard \geq DN 350 for 10 bar version

C. Seat		
Material	Code	Maximum temperature °C
EPDM	E	120
Nitrile	N	100

D. Box packing system		
Material	Code	Maximum temperature °C
TwinPack™ with bottom scraper in PTFE	TY	260
<i>Option:</i>		
Top scraper in PTFE	TS	260

Actuators

Manual	Code	Automatic	Code
Hand wheel ²⁾	HW	Pneumatic cylinder	EC
Chain wheel ³⁾	CW	Elektric motor	EM
Ratchet wrench ³⁾	RW	Hydraulic cylinder ²⁾	MH
Bevel gear ³⁾	BG		

²⁾ For recommended size, see page 5, column E.

³⁾ For recommended size, see separate datasheet.

Double-acting pneumatic cylinder type EC						Electric motor (AUMA multi-turn)		
DN valve	EC type	Force at 5 bar (kN)	DN valve 10 bar version	EC type	Force at 5 bar (kN)	DN valve	AUMA	Attachment
80	EC 100	3,5	80	EC 100	3,5	50 - 150	SA 07.2	F10/A
100 - 150	EC 125	5,5	100 - 150	EC 125	5,5	200 - 250	SA 07.6	F10/A
200 - 300	EC 160	9,0	200 - 300	EC 160	9,0	300 - 600	SA 10.2	F10/A
350 - 450	EC 200	14,1	350	EC 200	14,1			
500 - 600	EC 250	22,1	400 - 500	EC 250	22,1			
			600	EC 320	36,2			

The table above gives recommended cylinder sizes at normal option with 5 bar air pressure. For other operating conditions, please contact Stafsjö or your local representative for advice.

Electric motors are mounted according to standard ISO 5210. The table above gives recommended motor sizes at normal operation. For other operating conditions, please contact Stafsjö or your local representative for advice.

The actuators are described in separate data sheets. For advice and information on other actuators or on ATEX-classified ones, please contact Stafsjö or your local representative.

Specify the Stafsjö valve

Stafsjö's valves are modular designed and they can easily be customized with gate, seat and box packings according to media and requirements, as well for actuators and accessories. Below are examples of how you can specify your Stafsjö valve. Further information is available on www.stafsjo.com.

WB14E-E-200-E-TY-HW-PN10

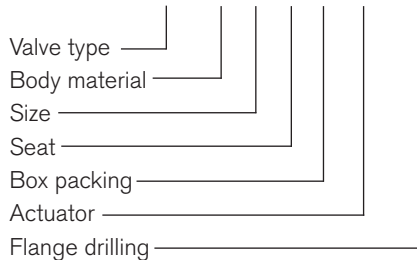

WB14E-E-200-N-TY-EC160-ANSI-ILS-SV

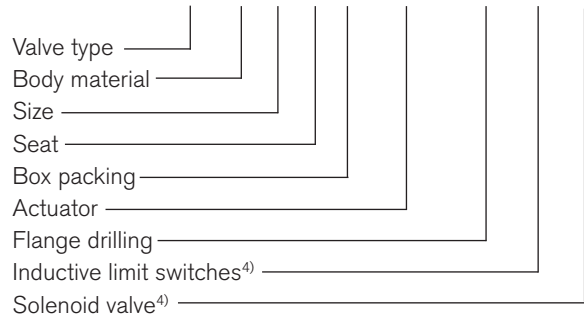

⁴⁾ All electronics must be specified in detail.

One piece valve body: DN 80 - DN 300

Two piece valve body: DN 350 - DN 600

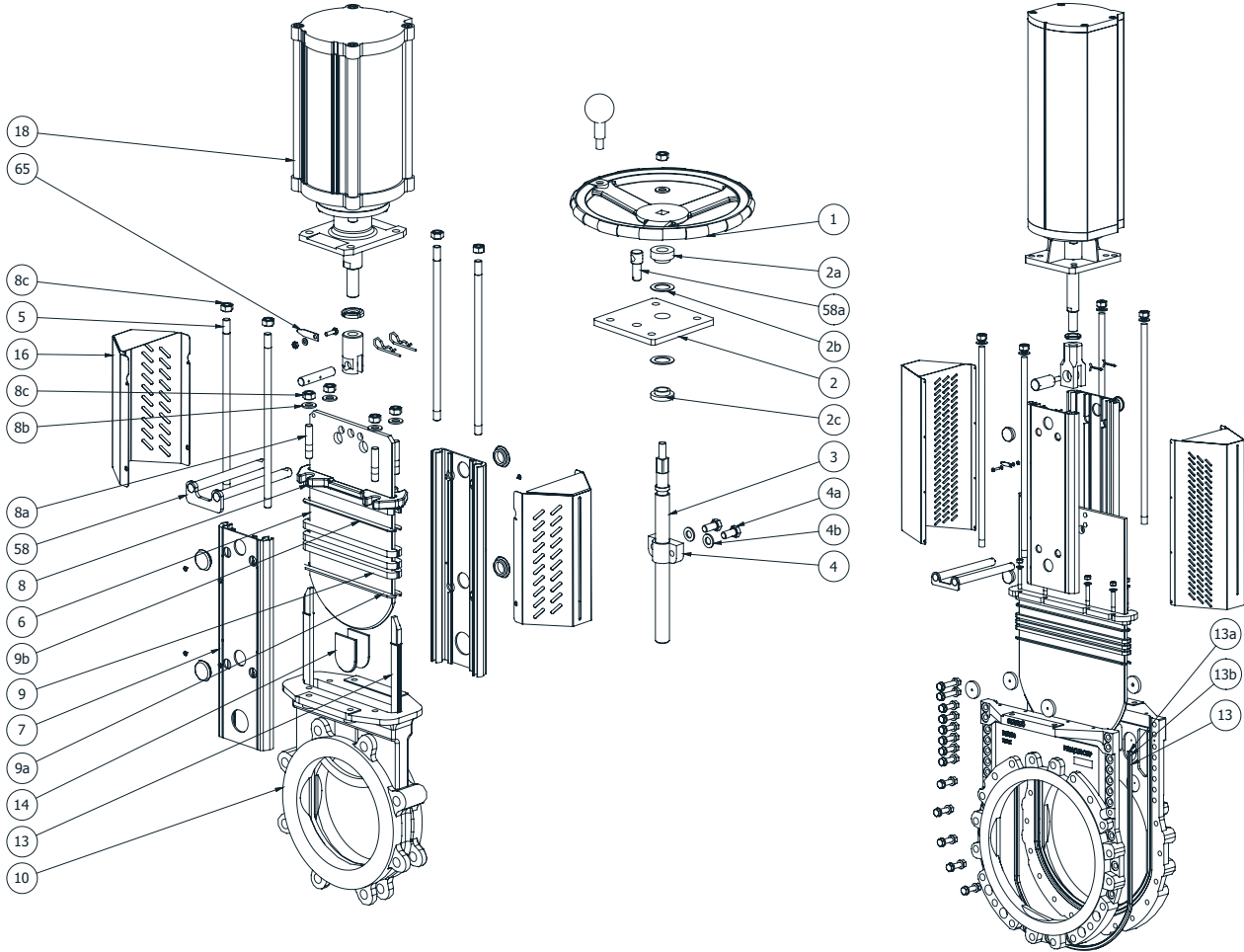

Part list

Pos.	Part	Material (Name)
1	Hand wheel	Coated cast iron Ø 250 - Ø 315 (EN-JL1040 (GG25)) ≥ Ø 400 (EN-JL1030 (GG20))
2	Yoke	Stainless steel (EN 1.4301)
2a	Bearing	Brass (CuZn39Pb3)
2b	Slide washer	POM
2c	Bearing	Brass (CuZn39Pb3)
3	Stem	Stainless steel (EN 1.4016)
4	Stem nut	Brass (CuZn39Pb3)
4a	Washer	Stainless steel (A2)
4b	Bolt	Stainless steel (A2)
5	Tie rod	Stainless steel (EN 1.4301)
6	Gate	See equipment B
7	Beam	Aluminum (EN AW-6063-T6)
8	Gland	Stainless steel (EN 1.4408)
8a	Stud bolt	Stainless steel (A2)
8b	Washer	Stainless steel (A2)

Pos.	Part	Material (Name)
8c	Nut	Stainless steel (A2)
9 ⁵⁾	Box packing	See equipment D
9a ⁵⁾	Box bottom scraper	See equipment D
9b ^{5, 6)}	Box top scraper	See equipment D
10	Valve body	See equipment A
13 ⁵⁾	Seat	See equipment C
16	Gate guard, not for HW	Stainless steel (EN 1.4301)
13 ⁵⁾	Sealing profile	See equipment C
13a ⁵⁾	Pin long	Stainless steel (EN 1.4301)
13b ⁵⁾	Pin short	Stainless steel (EN 1.4301)
14	Guiding pads	POM
18	Pneumatic cylinder	See separate datasheet
58/a ⁶⁾	Locking pin	Stainless steel (EN 1.4301)
65 ⁶⁾	Gate indicator	Stainless steel (EN 1.4301)

⁵⁾ Recommended spare parts

⁶⁾ Optional accessories

One piece valve body: DN 80 - DN 300

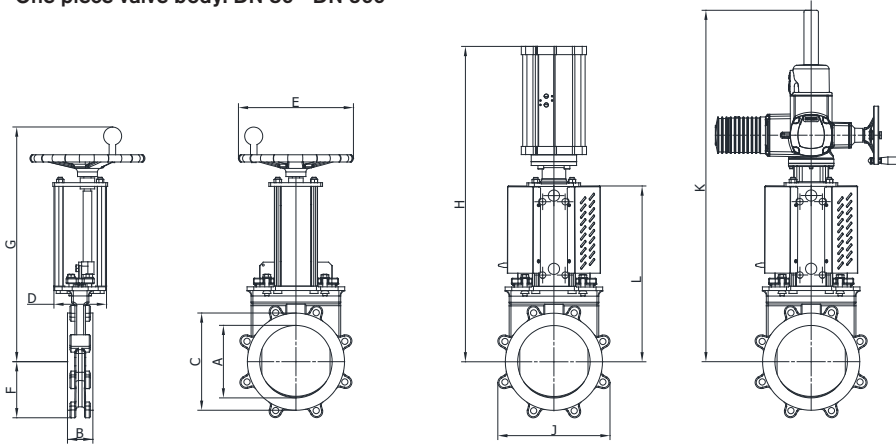

Two piece valve body: DN 350 - DN 600

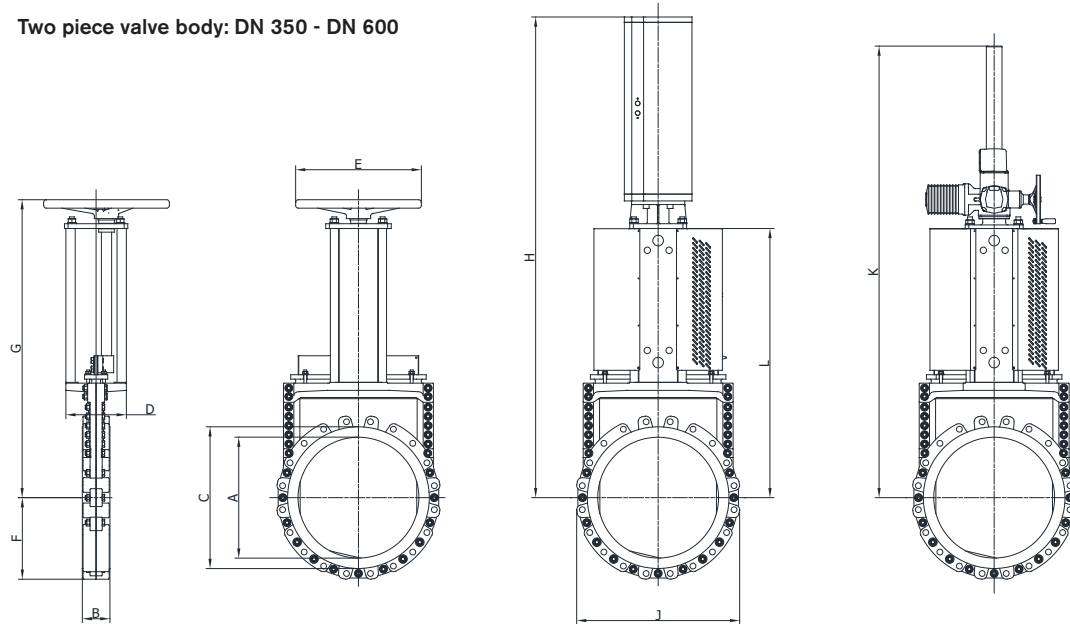

Main dimensions

Dimensions (mm)													
DN	A	B	C	D	E	F	G	H ⁷⁾	H ⁸⁾	J	K	L	Weight ⁹⁾
80	80	51	127	80	250	69	346	-	512	137	677	275	12
100	100	52	153	80	250	102	381	-	547	204	712	310	15
125	125	56	169	86	250	112	421	-	685	236	752	350	18
150	150	56	212	80	250	128	464	-	730	256	794	392	22
200	200	70	268	145	315	155	561	-	866	310	818	489	37
250	250	69	320	145	315	194	657	-	1050	388	914	579	55
300	300	78	372	148	315	231	753	-	1163	462	1059	675	71
350	350	78	430	180	400	251	880	1470	1470	501	1228	783	115
400	400	89	482	180	400	285	977	1565	1622	570	1375	880	155
450	450	89	532	250	520	308	1153	1821	1778	615	1636	1034	230
500	500	114	586	250	520	338	1225	1932	1932	675	1706	1113	270
600	600	114	686	250	520	400	1436	2191	2256	800	2018	1317	400

⁷⁾ Dimensions WB14E DN 350 - DN 450 6 bar version and DN 500 - DN 600 4 bar version.

⁸⁾ Dimensions WB14E DN 80 - DN 600 10 bar version.

⁹⁾ Weight in kg for valve equipped with hand wheel.

Main dimensions are only for information. Contact Stafsjö for certified drawings.

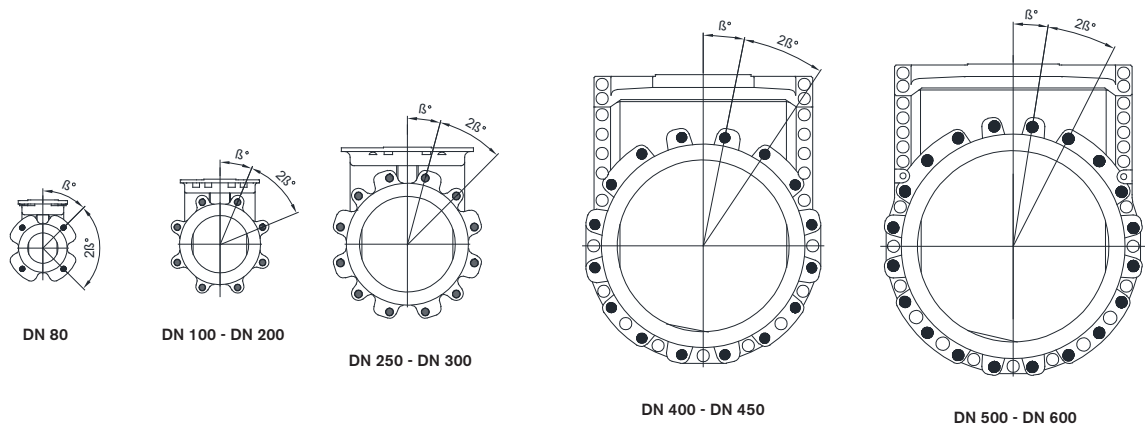

Flange drilling according to ASME/ANSI B 16.5 Class 150

Flange drilling information												
DN	80	100	125	150	200	250	300	350	400	450	500	600
Outside flange diameter (mm)	190,5	228,6	254	279,8	342,9	406,8	482,6	533,4	596,9	635	698,5	812,8
Bolt circle diameter (mm)	152,4	190,5	215,9	241,3	298,4	361,9	431,8	476,3	539,8	577,9	635	749,3
Number of throughgoing bolts (○)	-	-	-	-	-	-	-	-	-	-	-	-
Number of tapped hole on each side (●)	4	8	8	8	8	12	12	12	16	16	20	20
Boltsize (UNC)	5/8-11	5/8-11	3/4-10	3/4-10	3/4-10	7/8-9	7/8-9	1-8	1-8	1 1/8-7	1 1/8-7	1 1/4-7
β°	45	22,5	22,5	22,5	22,5	15	15	15	11,25	11,25	9	9
Screw lengths ⁹⁾	14	15	15	15	23	20	21	21	27	27	32	32

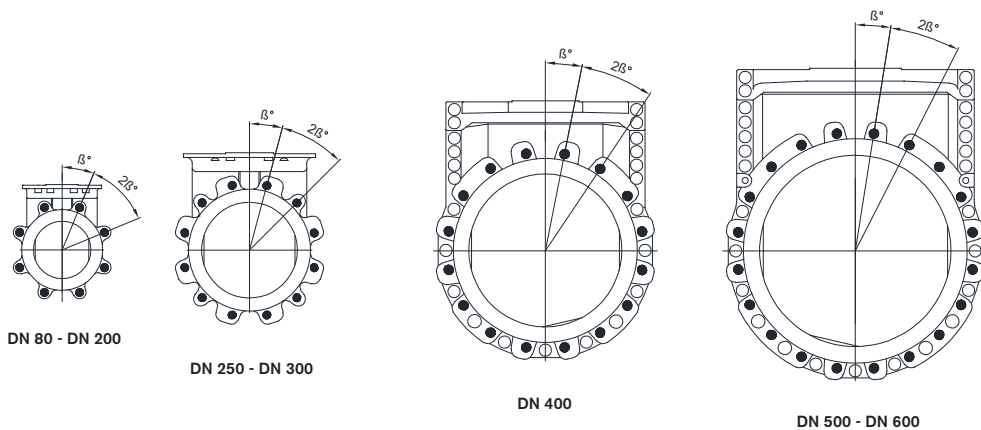

Flange drilling according to EN 1092 PN10

Flange drilling information												
DN	80	100	125	150	200	250	300	350	400	450	500	600
Outside flange diameter (mm)	200	220	250	285	340	395	445	OR	565	OR	670	780
Bolt circle diameter (mm)	160	180	210	240	295	350	400	OR	515	OR	620	725
Number of throughgoing bolts (○)	-	-	-	-	-	-	-	-	-	-	-	-
Number of tapped hole on each side (●)	8	8	8	8	8	12	12	OR	16	OR	20	20
Boltsize	M16	M16	M16	M20	M20	M20	M20	OR	M24	OR	M24	M27
β°	22,5	22,5	22,5	22,5	22,5	15	15	OR	11,25	OR	9	9
Screw lengths ⁹⁾	11	15	15	15	18	20	21	OR	27	OR	32	32

⁹⁾ Add the values with the thickness of flanges, washers and gaskets.

○ Throughgoing holes

● Tapped holes

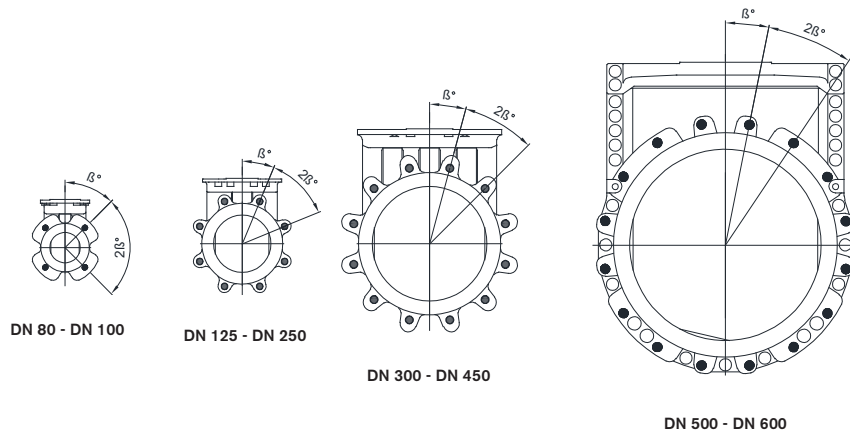

Flange drilling according to AS 2129 Table D

Flange drilling information												
DN	80	100	125	150	200	250	300	350	400	450	500	600
Outside flange diameter (mm)	185	215	255	280	335	405	455	525	580	640	705	825
Bolt circle diameter (mm)	146	178	210	235	292	356	406	470	521	584	641	756
Number of throughgoing bolts (○)	-	-	-	-	-	-	-	-	-	-	-	-
Number of tapped hole on each side (●)	4	4	8	8	8	8	12	12	12	12	16	16
Boltsize	M16	M16	M16	M16	M16	M20	M20	M24	M24	M24	M24	M27
β°	45	45	22,5	22,5	22,5	22,5	15	15	15	15	11,25	11,25
Screw lengths ⁹⁾	11	15	15	15	18	20	21	21	27	27	32	32

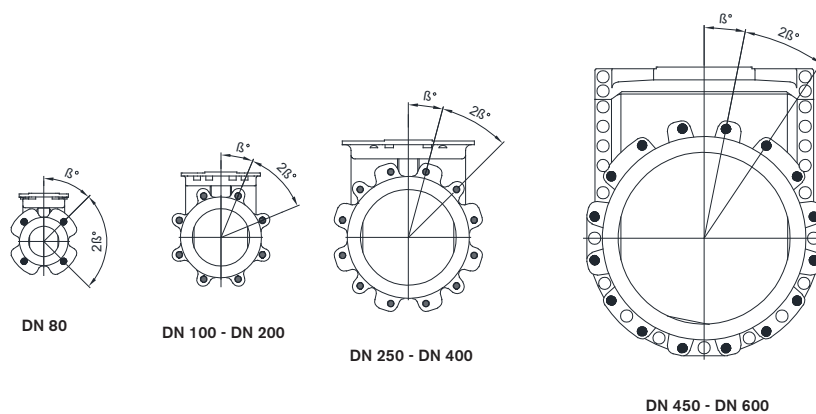

Flange drilling according to AS 2129 Table E

Flange drilling information												
DN	80	100	125	150	200	250	300	350	400	450	500	600
Outside flange diameter (mm)	185	215	255	280	335	405	455	525	580	640	705	825
Bolt circle diameter (mm)	146	178	210	235	292	356	406	470	521	584	641	756
Number of throughgoing bolts (○)	-	-	-	-	-	-	-	-	-	-	-	-
Number of tapped hole on each side (●)	4	8	8	8	8	12	12	12	12	16	16	16
Boltsize	M16	M16	M16	M20	M20	M20	M24	M24	M24	M24	M24	M30
β°	45	22,5	22,5	22,5	22,5	15	15	15	15	11,25	11,25	11,25
Screw lengths ⁹⁾	11	15	15	15	18	20	21	21	27	27	32	32

⁹⁾ Add the values with the thickness of flanges, washers and gaskets.

○ Throughgoing holes

● Tapped holes

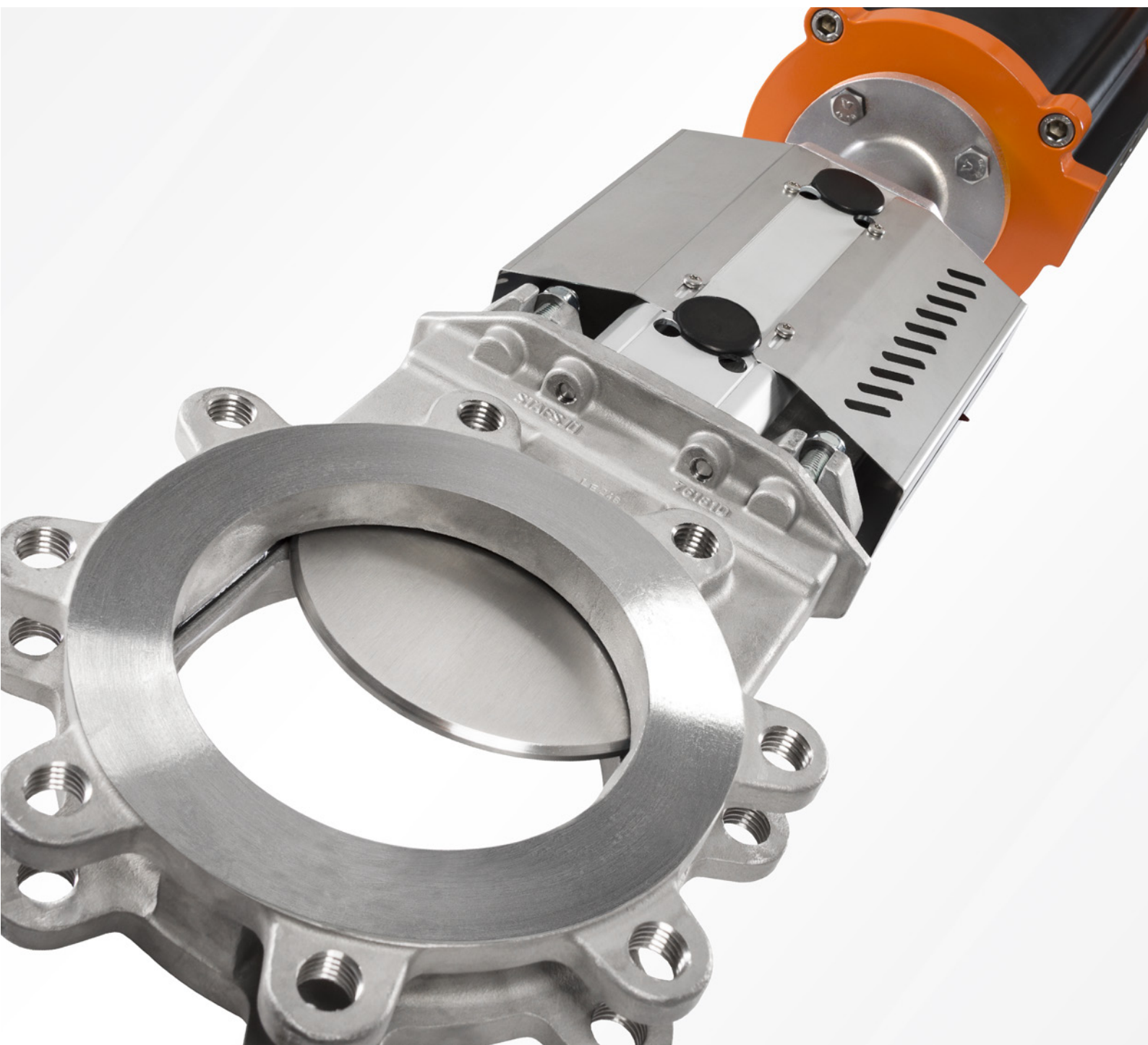

Архангельск (8182)63-90-72
Астана (7172)727-132
Астрахань (8512)99-46-04
Барнаул (3852)73-04-60
Белгород (4722)40-23-64
Брянск (4832)59-03-52
Владивосток (423)249-28-31
Волгоград (844)278-03-48
Вологда (8172)26-41-59
Воронеж (473)204-51-73
Екатеринбург (343)384-55-89
Иваново (4932)77-34-06

Ижевск (3412)26-03-58
Иркутск (395)279-98-46
Казань (843)206-01-48
Калининград (4012)72-03-81
Калуга (4842)92-23-67
Кемерово (3842)65-04-62
Киров (8332)68-02-04
Краснодар (861)203-40-90
Красноярск (391)204-63-61
Курск (4712)77-13-04
Липецк (4742)52-20-81
Киргизия (996)312-96-26-47

Магнитогорск (3519)55-03-13
Москва (495)268-04-70
Мурманск (8152)59-64-93
Набережные Челны (8552)20-53-41
Нижний Новгород (831)429-08-12
Новокузнецк (3843)20-46-81
Новосибирск (383)227-86-73
Омск (3812)21-46-40
Орел (4862)44-53-42
Оренбург (3532)37-68-04
Пенза (8412)22-31-16
Казахстан (772)734-952-31

Пермь (342)205-81-47
Ростов-на-Дону (863)308-18-15
Рязань (4912)46-61-64
Самара (846)206-03-16
Санкт-Петербург (812)309-46-40
Саратов (845)249-38-78
Севастополь (8692)22-31-93
Симферополь (3652)67-13-56
Смоленск (4812)29-41-54
Сочи (862)225-72-31
Ставрополь (8652)20-65-13
Россия (495)268-04-70

Сургут (3462)77-98-35
Тверь (4822)63-31-35
Томск (3822)98-41-53
Тула (4872)74-02-29
Тюмень (3452)66-21-18
Ульяновск (8422)24-23-59
Уфа (347)229-48-12
Хабаровск (4212)92-98-04
Челябинск (351)202-03-61
Череповец (8202)49-02-64
Ярославль (4852)69-52-93