

Архангельск (8182)63-90-72
Астана (7172)727-132
Астрахань (8512)99-46-04
Барнаул (3852)73-04-60
Белгород (4722)40-23-64
Брянск (4832)59-03-52
Владивосток (423)249-28-31
Волгоград (844)278-03-48
Вологда (8172)26-41-59
Воронеж (473)204-51-73
Екатеринбург (343)384-55-89
Иваново (4932)77-34-06

Ижевск (3412)26-03-58
Иркутск (395)279-98-46
Казань (843)206-01-48
Калининград (4012)72-03-81
Калуга (4842)92-23-67
Кемерово (3842)65-04-62
Киров (8332)68-02-04
Краснодар (861)203-40-90
Красноярск (391)204-63-61
Курск (4712)77-13-04
Липецк (4742)52-20-81
Киргизия (996)312-96-26-47

Магнитогорск (3519)55-03-13
Москва (495)268-04-70
Мурманск (8152)59-64-93
Набережные Челны (8552)20-53-41
Нижний Новгород (831)429-08-12
Новокузнецк (3843)20-46-81
Новосибирск (383)227-86-73
Омск (3812)21-46-40
Орел (4862)44-53-42
Оренбург (3532)37-68-04
Пенза (8412)22-31-16
Казахстан (772)734-952-31

Пермь (342)205-81-47
Ростов-на-Дону (863)308-18-15
Рязань (4912)46-61-64
Самара (846)206-03-16
Санкт-Петербург (812)309-46-40
Саратов (845)249-38-78
Севастополь (8692)22-31-93
Симферополь (3652)67-13-56
Смоленск (4812)29-41-54
Сочи (862)225-72-31
Ставрополь (8652)20-65-13
Россия (495)268-04-70

Сургут (3462)77-98-35
Тверь (4822)63-31-35
Томск (3822)98-41-53
Тула (4872)74-02-29
Тюмень (3452)66-21-18
Ульяновск (8422)24-23-59
Уфа (347)229-48-12
Хабаровск (4212)92-98-04
Челябинск (351)202-03-61
Череповец (8202)49-02-64
Ярославль (4852)69-52-93

<https://ebro-armaturen.nt-rt.ru/> || ero@nt-rt.ru

Knife gate valve

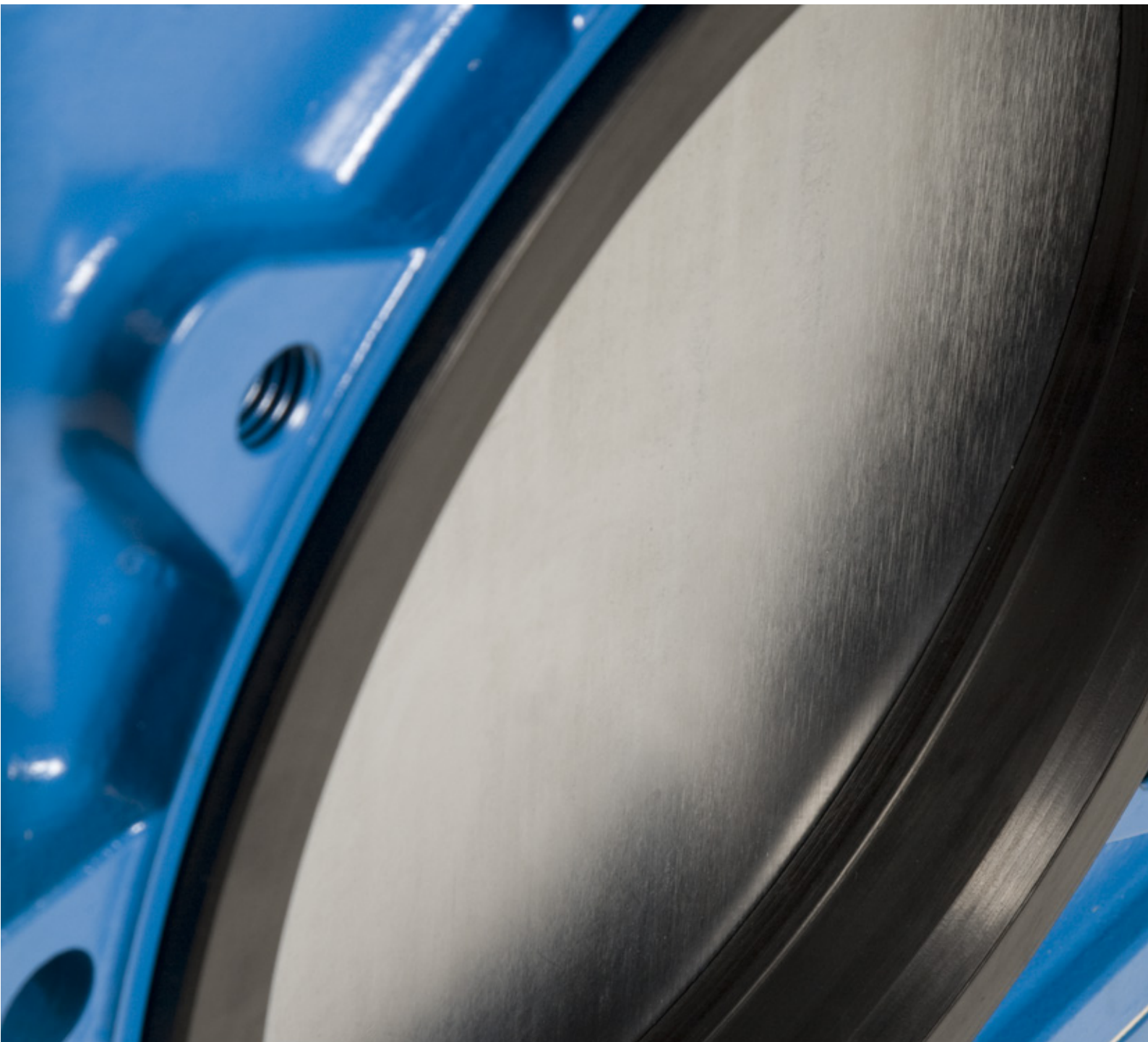

Knife gate valve SLV

Stafsjö's knife gate valve SLV is a full bore valve particularly suitable for the most abrasive and demanding slurry where operation reliability and low life cycle cost are emphasized.

When the valve is in opened position, the seats form a tight extension of the pipe line and no metal parts are in contact with the media. When the valve closes the two seats are displaced axially forming a seal with the gate until it forms a complete closure – 100% tight in any pressure direction.

The SLV comes with a coated lugged valve body in nodular iron with integrated purge ports in the lower end to be utilized if a bottom cover is assembled on the valve. The unique seats are available in low friction special EPDM, natural rubber or Viton. These seal against a gate in duplex stainless steel specially machined and grinded to reduce the friction when the valve is operated. It can also be supplied hard chromed to give a really hard and wear resistant surface. The gland box system is as standard supplied with three layers of our TwinPack™ and a box bottom scraper in order to give a first-rate sealing and a straight gate guidance.

The top works is modular designed and there are several actuator types and accessories to choose from in our standard collection – all easily exchangeable between each other. For security reason the valve is always supplied ready to be locked in either opened or closed position.

The SLV valve is designed, manufactured, inspected and tested according to pressure equipment directive 2014/68/EU category I and II module A2. The valve is CE marked when it is applicable.

Other slurry valves are the fully flanged SLF and the high pressure versions SLH and SLX which can be supplied for pressures up to 50 bar.

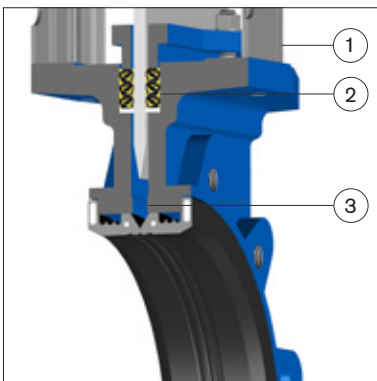

A precise gate guidance extend the valve's service life

A solid top works (1), a robust gland box system (2), precisely machined gate supports (3) is crucial during operation to keep the gate in position and to minimize the wear on the seats.

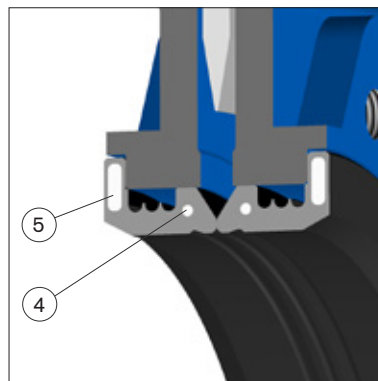

Built in steel reinforcements improve the performance

The front reinforcement rings (4) ensure the seats shape, position and strength remain during operation while the flange sealing reinforcements (5) secure a tight and exact position of the seats towards the gate and connecting flanges.

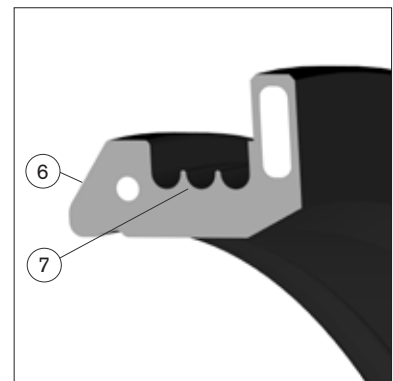

Integrated expansion areas give low operating force and minimize the stress on the seats

The seat entrance area (6) is designed to give a smooth gate entry and the expansion areas (7) allows the seat to be axially flexible requiring minimal operating force.

Design data

Sizes	Flange drilling	Face-to-face dimension	Corrosion protection
DN 50 - DN 900	EN 1092 PN 10 AS 2129 Table D AS 2129 Table E ASME/ANSI B16.5 Class 150, ASME/ ANSI B16.47 Class 150 series A	Stafsjö manufacturing standard	Non-corrosive resistant materials are coated in colour RAL5015 acc. to Stafsjö's standard, which fulfill the requirements in EN ISO 12944 class C3.

Other sizes, flange drillings and corrosion protection on request.

Leakage rate	Pressure tests
EN 12266-1:2009 Rate A: no visually detectable leakage is allowed for duration of the test.	Pressure tests are performed with water at 20° C according to EN 12266-1:2009. Pressure shell test: 1,5 times maximum allowable working pressure for open valve. Pressure seat tightness test: 1,1 times maximum allowable differential pressure for closed valve.

Maximum working pressure body at 20°C		Maximum differential pressure at 20°C	
DN	bar	DN	bar
50 - 600	10	50 - 400	10
700 - 900	5	450 - 600	6 (10 bar on request)
		700 - 900	5

Basic equipment

A. Valve Body			
Material	Code	Type	Maximum temperature °C
Nodular iron	L	EN 5.3105, EN-JS1050	200

The valve body is as standard supplied with purge ports: DN 50-DN 200:1/2", DN 250-DN 400: 3/4", DN 500-DN 600 1", DN 700-DN 800 1 1/2"

B. Gate		
Material standard	Type	Option
Duplex stainless steel	EN 1.4462 (S32205)	Hard chromed surface

Other materials on request.

C. Seats		
Material	Code	Maximum temperature °C
EPDM	E	120
Natural rubber	NR	80
Viton	V	180

D. Box packing		
Material	Code	Maximum temperature °C
TwinPack™ with scraper in UHMW-PE	TY	80

Actuators

Manual	Code	Automatic	Code
Hand wheel¹⁾	HWR	Pneumatic cylinder	EC
Bevel gear²⁾	BG	Electrical motor	EM
		Hydraulic cylinder²⁾	MH

¹⁾ For recommended size, see page 5 column E

²⁾ For recommended size, see separate data sheet

Double-acting pneumatic cylinder			Electric motor (AUMA multi-turn)		
DN valve	Size EC	Force at 5 bar (kN)	DN valve	AUMA type	Attachment
50 - 65	EC 100	3,5	50 - 80	SA 07.2	F10/A
80 - 150	EC 160	9,0	100 - 125	SA 07.6	F10/A
200 - 250	EC 200	14,1	150 - 350	SA 10.2	F10/A
300 - 350	EC 250	22,1	400 - 600	SA 14.2	F14/A
400 - 450	EC 320	36,2	700 - 900	SA 14.6	F14/A
500 - 600	EC 400	56,2			
≥ 700	On request				

The table above gives recommended cylinder sizes at normal operation with 5 bar air pressure. For other operating conditions, please contact Stafsjö or your local representative for advice.

Electric motors are mounted according to standard ISO 5210. The table above gives recommended motor sizes at normal operation. For other operating conditions, please contact Stafsjö or your local representative for advice.

The actuators are described in separate data sheets. For advice and information on other actuators or on ATEX-classified ones, please contact Stafsjö or your local representative.

Specify the Stafsjö valve

Stafsjö's valves are modular designed and they can easily be customized with gate, seats and box packings according to media and requirements, as well for actuators and accessories. Below is an example of how you can specify your Stafsjö valve. Further information is available on www.stafsjo.com.

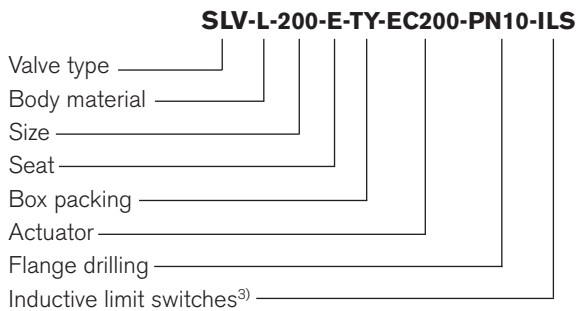

³⁾ All electronics must be specified in detail.

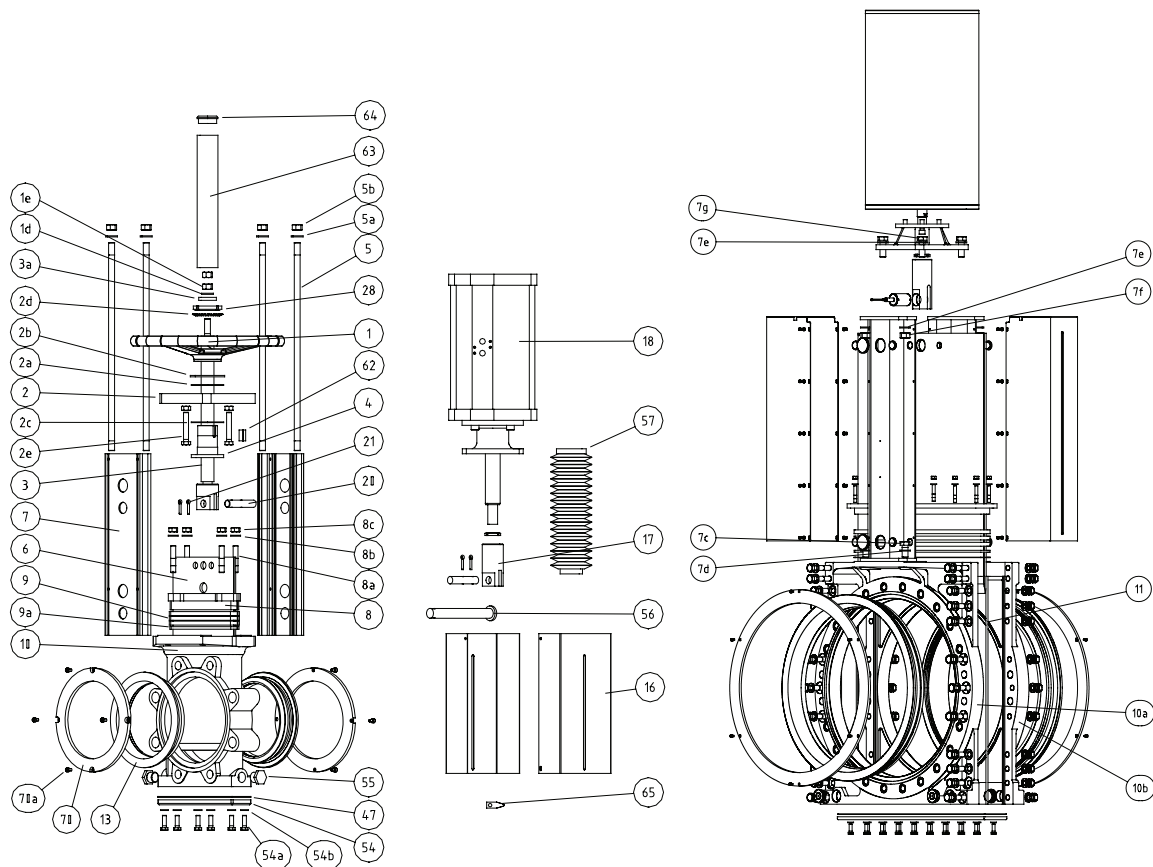

Part list

Pos.	Part	Material (type)
1	Hand wheel	Coated cast iron Ø 315 (EN-JL1040 (GG25)) ≥ Ø 400 (EN-JL1030 (GG20))
2	Yoke	Coated steel (EN 1.0038)
2a	Bearing	Iglidur XTM
2b	Slide washer	Brass (CW614N)
2c	Bearing	Iglidur XTM
2d	Washer	Stainless steel (EN 1.4305)
2e	Screw	Steel, zinc coated
3	Stem with gate clevis	Stainless steel (EN 1.4305) ≥ DN 350: Gate clevis in coated carbon steel (EN 1.0045)
3a	Stop washer	Stainless steel (EN 1.4301)
3b	Screw	Stainless steel (A2)
3c	Washer	Stainless steel (A2)
4	Stem nut	Brass (CW614N)
5	Tie rod	≤ DN 300: Stainless steel (EN 1.4301)
5a ⁵⁾	Washer	Stainless steel (A2)
5b ⁵⁾	Nut	Stainless steel (A2)
6	Gate	See equipment B
7	Beam	≤ DN 300: Aluminium (EN AW-6063-T6) ≥ DN 350: Coated steel (EN 1.0038)
7c	Screw	Steel, zinc coated
7d	Washer	Steel, zinc coated
7e	Washer	Steel, zinc coated
7f	Nut	Steel, zinc coated
7g	Screw	Steel, zinc coated
8	Gland	Coated nodular iron (EN-JS1050 (GGG50))
8a	Stud bolt	Stainless steel (A2), zinc coated
8b	Washer	Stainless steel (A2)
8c	Nut	Stainless steel (A2), zinc coated

Pos.	Part	Material (type)
9 ⁵⁾	Box packing	See equipment D
9a ⁵⁾	Box bottom scraper	See equipment D
10/a/b	Valve body	See equipment A
11	Body gasket	PTFE
13 ⁵⁾	Seat	See equipment C
16	Gate guard, not for HW	Stainless steel (EN 1.4301)
17	Gate clevis	Stainless steel (EN 1.4305) ≥ DN 350: Coated carbon steel (EN 1.0045)
18	Cylinder	See data sheet
20	Clevis pin	Stainless steel (EN 1.4305)
21	Split pin	Stainless steel (EN 1.4436)
47 ⁴⁾	Gasket	Dixo 4000
54 ⁴⁾	Bottom cover	See data sheet for Stafsjö's accessories
54a ⁴⁾	Screw	See data sheet for Stafsjö's accessories
54b ⁴⁾	Washer	See data sheet for Stafsjö's accessories
55	Plug	Steel, zinc coated
56 ⁴⁾	Locking pin	See data sheet for Stafsjö's accessories
57 ⁴⁾	Stem/piston rod protection	See data sheet for Stafsjö's accessories
62	Wedge	Stainless steel
63	Stemtube	Coated steel (EN 1.0038)
64	Plug	Plastic
65	Gate indicator	Stainless steel (EN 1.4436)
70 ⁴⁾	Load distribution rings	See data sheet for Stafsjö's accessories
70a ⁴⁾	Screws	See data sheet for Stafsjö's accessories

⁴⁾ Optional accessories

⁵⁾ Recommended spare parts

⁶⁾ ≥ DN 350 details are replaced by screws, washers and nuts.

SLV with load distribution rings (LDR)

SLV without load distribution rings

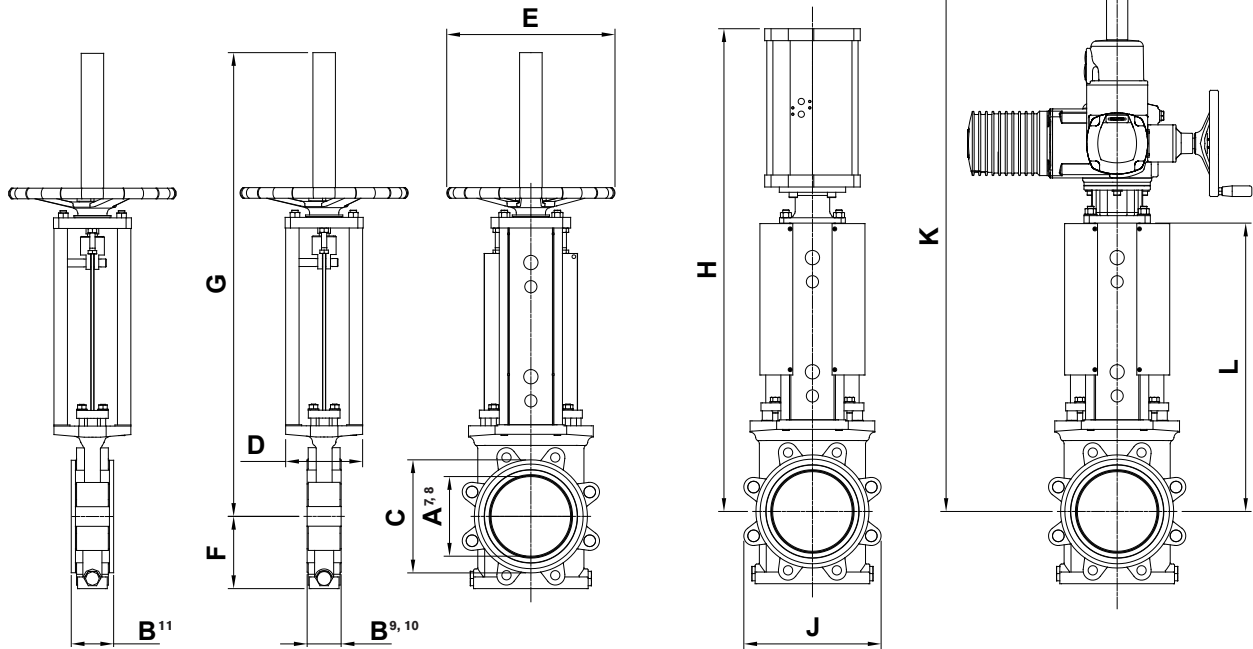

Main dimensions

Dimensions (mm)															
DN	A ⁷⁾	A ⁸⁾	B ⁹⁾	B ¹⁰⁾	B ¹¹⁾	C	D	E	F	G	H	J	K	L	Weight ¹²⁾
50	50	55	56	54	66	94	80	315	86	614	609	124	753	371	13
65	65	71	56	54	66	107	80	315	93	624	619	139	763	381	14
80	80	83	59	57	69	126	80	315	94	712	729	180	801	419	18
100	100	107	59	57	73	158	80	315	103	748	789	206	836	454	25
125	125	132	66	64	80	186	145	315	124	868	899	237	971	533	31
150	150	159	66	64	80	213	145	315	136	878	909	259	981	543	35
200	200	207	78	76	92	269	145	315	169	1031	1119	312	1079	641	44
250	250	260	78	76	96	322	145	400	204	1162	1251	388	1261	723	63
300	300	310	84	82	102	372	175	520	236	1400	1485	457	1409	861	98
350	350	350	84	82	102	434	200	520	266	1510	1610	516	1569	916	136
400	400	400	97	95	115	483	200	635	300	1650	1737	575	1701	998	176
450	450	450	97	95	115	533	300	-	330	-	1935	627	1942	1129	215
500	500	504	123	121	141	589	300	-	364	-	2019	680	2000	1187	270
600	600	600	123	121	141	690	300	-	425	-	2324	816	2290	1377	340
700	660	700	174	170	190	798	310	-	482	-	-	920	2551	1538	500
800	750	800	194	190	210	905	310	-	544	-	-	1040	2817	1704	660
900	850	900	225	220	240	1005	500	-	594	-	-	1154	3086	1858	900

A⁷⁾ Bore diameter. A⁸⁾ Inlet diameter.

B⁹⁾ Minimum required face-to-face for installation without load distribution rings. B¹⁰⁾ Installed face-to-face without load distribution rings.

B¹¹⁾ Installed face-to-face with load distribution rings (LDR). When the pipe line or connecting flanges are rubber lined or when they do not cover the metal frame around the seats (dimension C), there is a need to install load distribution rings between the SLV and the flanges to avoid functional problems and to ensure the seats will stay in correct position after every valve manoeuvring. If load distribution rings are ordered they are as standard assembled on the valve upon delivery.

¹²⁾ Weight in kg for valve including hand wheel with rising stem (HWR), ≥ DN 450 prepared for bevel gear or electric actuator.

Main dimensions are only for information. Contact Stafsjö for certified drawings.

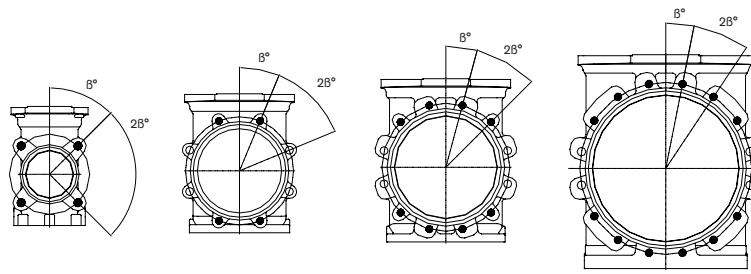

DN 50-DN 65

DN 80-DN 200

DN 250-DN 300

DN 350-DN 400

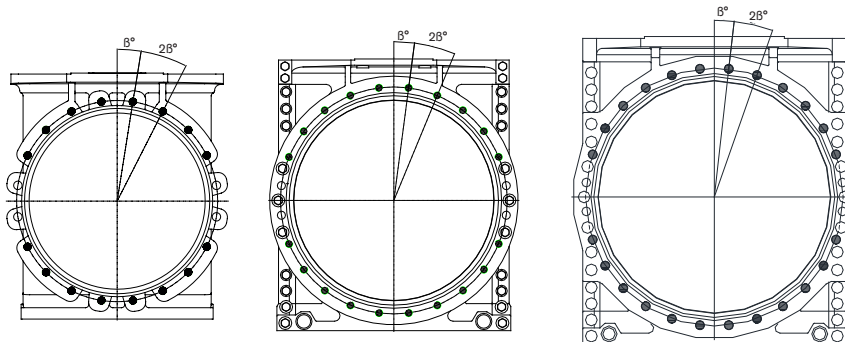

DN 450-DN 600

DN 700-DN 800

DN 900

Flange drilling according to EN 1092 PN 10

Flange drilling information (mm)									
DN	50	65	80	100	125	150	200	250	300
Outside flange diameter	165	185	200	220	250	285	340	395	445
Bolt circle diameter	125	145	160	180	210	240	295	350	400
Number of throughgoing holes (◦)	-	-	4	4	4	4	4	4	4
Number of tapped holes on each side (●)	4	4	4	4	4	4	4	8	8
Bolt size	M16	M16	M16	M16	M16	M20	M20	M20	M20
Size of throughgoing holes	-	-	Ø18	Ø18	Ø18	Ø22	Ø22	Ø22	Ø22
β°	45	45	22,5	22,5	22,5	22,5	22,5	15	15
Depth of tapped holes ¹³⁾	15	15	14	14	16	16	20	19	22
Flange drilling information (mm)									
DN	350	400	450	500	600	700	800	900	
Outside flange diameter	505	565	615	670	780	895	1015	1115	
Bolt circle diameter	460	515	565	620	725	840	950	1050	
Number of throughgoing holes (◦)	4	4	4	4	4	4	4	4	
Number of tapped holes on each side (●)	12	12	16	16	16	20	20	24	
Bolt size	M20	M24	M24	M24	M27	M27	M30	M30	
Size of throughgoing holes	Ø22	Ø26	Ø26	Ø26	Ø30	Ø30	Ø33	Ø33	
β°	15	11,25	9	9	9	7,5	7,5	6,43	
Depth of tapped holes ¹³⁾	22	25	23	34	32	49	59	67	

¹³⁾ Add the values with the thickness of flanges and washers.

◦ Throughgoing holes

● Tapped holes

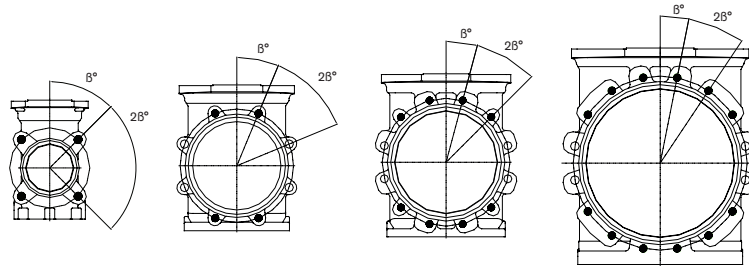

DN 50-DN 80

DN 100-DN 200

DN 250-DN 350

DN 400-DN 450

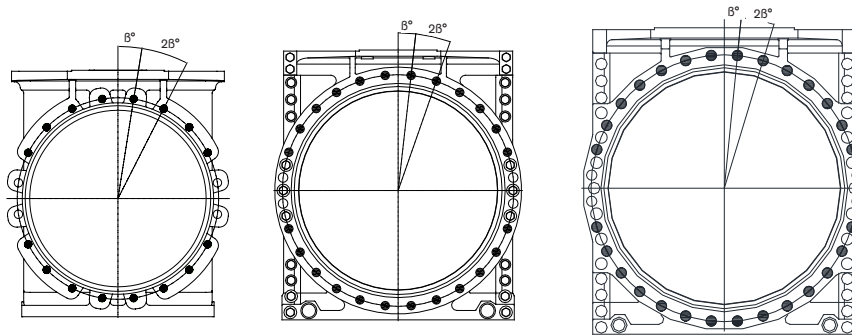

DN 500-DN 600

DN 700-DN 800

DN 900

Flange drilling according to ANSI/ASME B16.5 and 16.47 Class 150

Flange drilling information (mm)									
DN	50	65	80	100	125	150	200	250	300
Outside flange diameter	152,4	177,8	190,5	228,6	254	297,4	342,9	406,4	482,6
Bolt circle diameter	120,7	139,7	152,4	190,5	215,9	241,3	298,5	362	431,8
Number of throughgoing holes (◌)	-	-	-	4	4	4	4	4	4
Number of tapped holes on each side (●)	4	4	4	4	4	4	4	8	8
Bolt size (UNC)	5/8"-11	5/8"-11	5/8"-11	5/8"-11	3/4"-10	3/4"-10	3/4"-10	7/8"-9	7/8"-9
Size of throughgoing holes	-	-	-	Ø18	Ø22	Ø22	Ø22	Ø26	Ø26
β°	45	45	45	22,5	22,5	22,5	22,5	15	15
Depth of tapped holes ¹³⁾	15	15	14	14	16	16	20	19	22
Flange drilling information (≥ DN 700: ASME/ANSI B16.47 Class 150 series A) (mm)									
DN	350	400	450	500	600	700	800	900	
Outside flange diameter	533,4	596,9	635	698,5	812,8	927,1	1060,5	1168,4	
Bolt circle diameter	476,3	539,8	577,9	635	749,3	863,6	977,9	1085,9	
Number of throughgoing holes (◌)	4	4	4	4	4	4	4	4	
Number of tapped holes on each side (●)	8	12	12	16	16	24	24	28	
Bolt size (UNC)	1"-8	1"-8	1 1/8"-7	1 1/8"-7	1 1/4"-7	1 1/4"-7	1 1/4"-6	1 1/2"-6	
Size of throughgoing holes	Ø30	Ø30	Ø33	Ø33	Ø36	Ø36	Ø42	Ø42	
β°	15	11,25	11,25	9	9	6,43	6,43	5,63	
Depth of tapped holes ¹³⁾	21	25	23	34	32	49	59	67	

¹³⁾ Add the values with the thickness of flanges and washers.

◌ Throughgoing holes

● Tapped holes

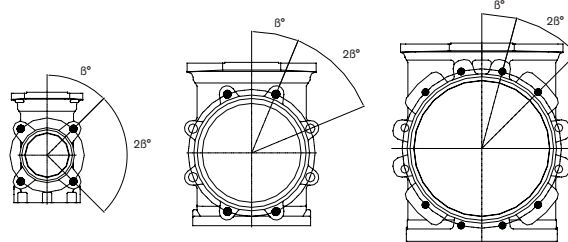

DN 50-DN 100

DN 125-DN 250

DN 300-DN 450

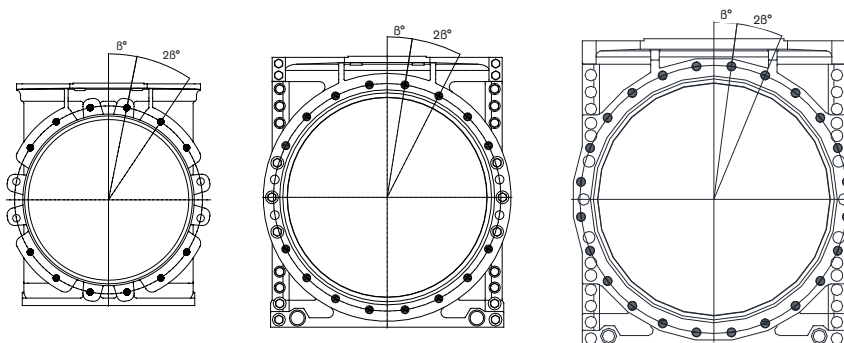

DN 500-DN 600

DN 700-DN 800

DN 900

Flange drilling according to AS 2129 Table D

Flange drilling information (mm)									
DN	50	65	80	100	125	150	200	250	300
Outside flange diameter	150	165	185	215	255	280	335	405	455
Bolt circle diameter	114	127	146	178	210	235	292	356	406
Number of throughgoing holes (◊)	-	-	-	-	4	4	4	4	4
Number of tapped holes on each side (●)	4	4	4	4	4	4	4	4	8
Bolt size	M16	M16	M16	M16	M16	M16	M16	M20	M20
Size of throughgoing holes	-	-	-	Ø18	Ø18	Ø18	Ø18	Ø22	Ø22
β°	45	45	45	45	22,5	22,5	22,5	22,5	15
Depth of tapped holes ¹⁴⁾	15	15	14	14	16	16	20	19	22
Flange drilling information (mm)									
DN	350	400	450	500	600	700	800	900	
Outside flange diameter	525	580	640	705	825	910	1060	1175	
Bolt circle diameter	470	521	584	641	756	845	984	1092	
Number of throughgoing holes (◊)	4	4	4	4	4	4	4	4	
Number of tapped holes on each side (●)	8	8	8	12	12	16	16	20	
Bolt size	M24	M24	M24	M24	M27	M27	M33	M33	
Size of throughgoing holes	Ø26	Ø26	Ø26	Ø26	Ø30	Ø30	Ø36	Ø36	
β°	15	15	15	11,25	11,25	9	9	7,5	
Depth of tapped holes ¹³⁾	21	25	23	34	32	49	59	67	

¹³⁾ Add the values with the thickness of flanges and washers.

◊ Throughgoing holes

● Tapped holes

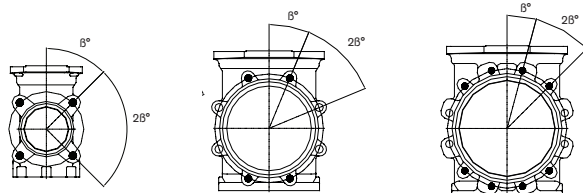

DN 50-DN 80

DN 100-DN 200

DN 250-DN 400

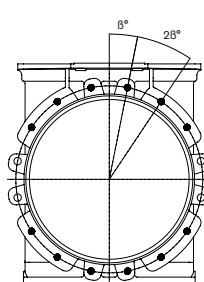

DN 450-DN 600

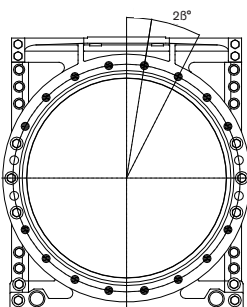

DN 700-DN 800

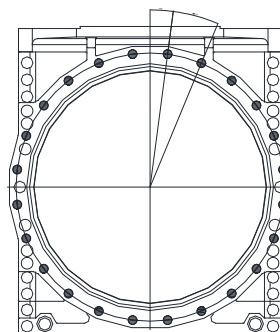

DN 900

Flange drilling according to AS 2129 Table E

Flange drilling information (mm)									
DN	50	65	80	100	125	150	200	250	300
Outside flange diameter	150	165	185	215	255	280	335	405	455
Bolt circle diameter	114	127	146	178	210	235	292	356	406
Number of throughgoing holes (°)	-	-	-	4	4	4	4	4	4
Number of tapped holes on each side (•)	4	4	4	4	4	4	4	8	8
Bolt size	M16	M16	M16	M16	M16	M20	M20	M20	M24
Size of throughgoing holes	-	-	-	Ø18	Ø18	Ø22	Ø22	Ø22	Ø26
β°	45	45	45	22,5	22,5	22,5	22,5	15	15
Depth of tapped holes ¹³⁾	15	15	14	14	16	16	20	19	22
Flange drilling information (mm)									
DN	350	400	450	500	600	700	800	900	
Outside flange diameter	525	580	640	705	825	910	1060	1175	
Bolt circle diameter	470	521	584	641	756	845	984	1092	
Number of throughgoing holes (°)	4	4	4	4	4	4	4	4	
Number of tapped holes on each side (•)	8	8	12	12	12	16	16	20	
Bolt size	M24	M24	M24	M24	M30	M30	M33	M33	
Size of throughgoing holes	Ø26	Ø26	Ø26	Ø26	Ø33	Ø33	Ø36	Ø36	
β°	15	15	11,25	11,25	11,25	9	9	7,5	
Depth of tapped holes ¹³⁾	21	25	23	34	32	49	59	67	

¹³⁾ Add the values with the thickness of flanges and washers.

° Throughgoing holes

• Tapped holes

Архангельск (8182)63-90-72
 Астана (7172)727-132
 Астрахань (8512)99-46-04
 Барнаул (3852)73-04-60
 Белгород (4722)40-23-64
 Брянск (4832)59-03-52
 Владивосток (423)249-28-31
 Волгоград (844)278-03-48
 Вологда (8172)26-41-59
 Воронеж (473)204-51-73
 Екатеринбург (343)384-55-89
 Иваново (4932)77-34-06

Ижевск (3412)26-03-58
 Иркутск (395)279-98-46
 Казань (843)206-01-48
 Калининград (4012)72-03-81
 Калуга (4842)92-23-67
 Кемерово (3842)65-04-62
 Киров (8332)68-02-04
 Краснодар (861)203-40-90
 Красноярск (391)204-63-61
 Курск (4712)77-13-04
 Липецк (4742)52-20-81
 Киргизия (996)312-96-26-47

Магнитогорск (3519)55-03-13
 Москва (495)268-04-70
 Мурманск (8152)59-64-93
 Набережные Челны (8552)20-53-41
 Нижний Новгород (831)429-08-12
 Новокузнецк (3843)20-46-81
 Новосибирск (383)227-86-73
 Омск (3812)21-46-40
 Орел (4862)44-53-42
 Оренбург (3532)37-68-04
 Пенза (8412)22-31-16
 Казахстан (772)734-952-31

Пермь (342)205-81-47
 Ростов-на-Дону (863)308-18-15
 Рязань (4912)46-61-64
 Самара (846)206-03-16
 Санкт-Петербург (812)309-46-40
 Саратов (845)249-38-78
 Севастополь (8692)22-31-93
 Симферополь (3652)67-13-56
 Смоленск (4812)29-41-54
 Сочи (862)225-72-31
 Ставрополь (8652)20-65-13
 Россия (495)268-04-70

Сургут (3462)77-98-35
 Тверь (4822)63-31-35
 Томск (3822)98-41-53
 Тула (4872)74-02-29
 Тюмень (3452)66-21-18
 Ульяновск (8422)24-23-59
 Уфа (347)229-48-12
 Хабаровск (4212)92-98-04
 Челябинск (351)202-03-61
 Череповец (8202)49-02-64
 Ярославль (4852)69-52-93