

Архангельск (8182)63-90-72  
Астана (7172)727-132  
Астрахань (8512)99-46-04  
Барнаул (3852)73-04-60  
Белгород (4722)40-23-64  
Брянск (4832)59-03-52  
Владивосток (423)249-28-31  
Волгоград (844)278-03-48  
Вологда (8172)26-41-59  
Воронеж (473)204-51-73  
Екатеринбург (343)384-55-89  
Иваново (4932)77-34-06

Ижевск (3412)26-03-58  
Иркутск (395)279-98-46  
Казань (843)206-01-48  
Калининград (4012)72-03-81  
Калуга (4842)92-23-67  
Кемерово (3842)65-04-62  
Киров (8332)68-02-04  
Краснодар (861)203-40-90  
Красноярск (391)204-63-61  
Курск (4712)77-13-04  
Липецк (4742)52-20-81  
Киргизия (996)312-96-26-47

Магнитогорск (3519)55-03-13  
Москва (495)268-04-70  
Мурманск (8152)59-64-93  
Набережные Челны (8552)20-53-41  
Нижний Новгород (831)429-08-12  
Новокузнецк (3843)20-46-81  
Новосибирск (383)227-86-73  
Омск (3812)21-46-40  
Орел (4862)44-53-42  
Оренбург (3532)37-68-04  
Пенза (8412)22-31-16  
Казахстан (772)734-952-31

Пермь (342)205-81-47  
Ростов-на-Дону (863)308-18-15  
Рязань (4912)46-61-64  
Самара (846)206-03-16  
Санкт-Петербург (812)309-46-40  
Саратов (845)249-38-78  
Севастополь (8692)22-31-93  
Симферополь (3652)67-13-56  
Смоленск (4812)29-41-54  
Сочи (862)225-72-31  
Ставрополь (8652)20-65-13  
Россия (495)268-04-70

Сургут (3462)77-98-35  
Тверь (4822)63-31-35  
Томск (3822)98-41-53  
Тула (4872)74-02-29  
Тюмень (3452)66-21-18  
Ульяновск (8422)24-23-59  
Уфа (347)229-48-12  
Хабаровск (4212)92-98-04  
Челябинск (351)202-03-61  
Череповец (8202)49-02-64  
Ярославль (4852)69-52-93

<https://ebro-armaturen.nt-rt.ru/> || [ero@nt-rt.ru](mailto:ero@nt-rt.ru)

## Knife gate valve TV

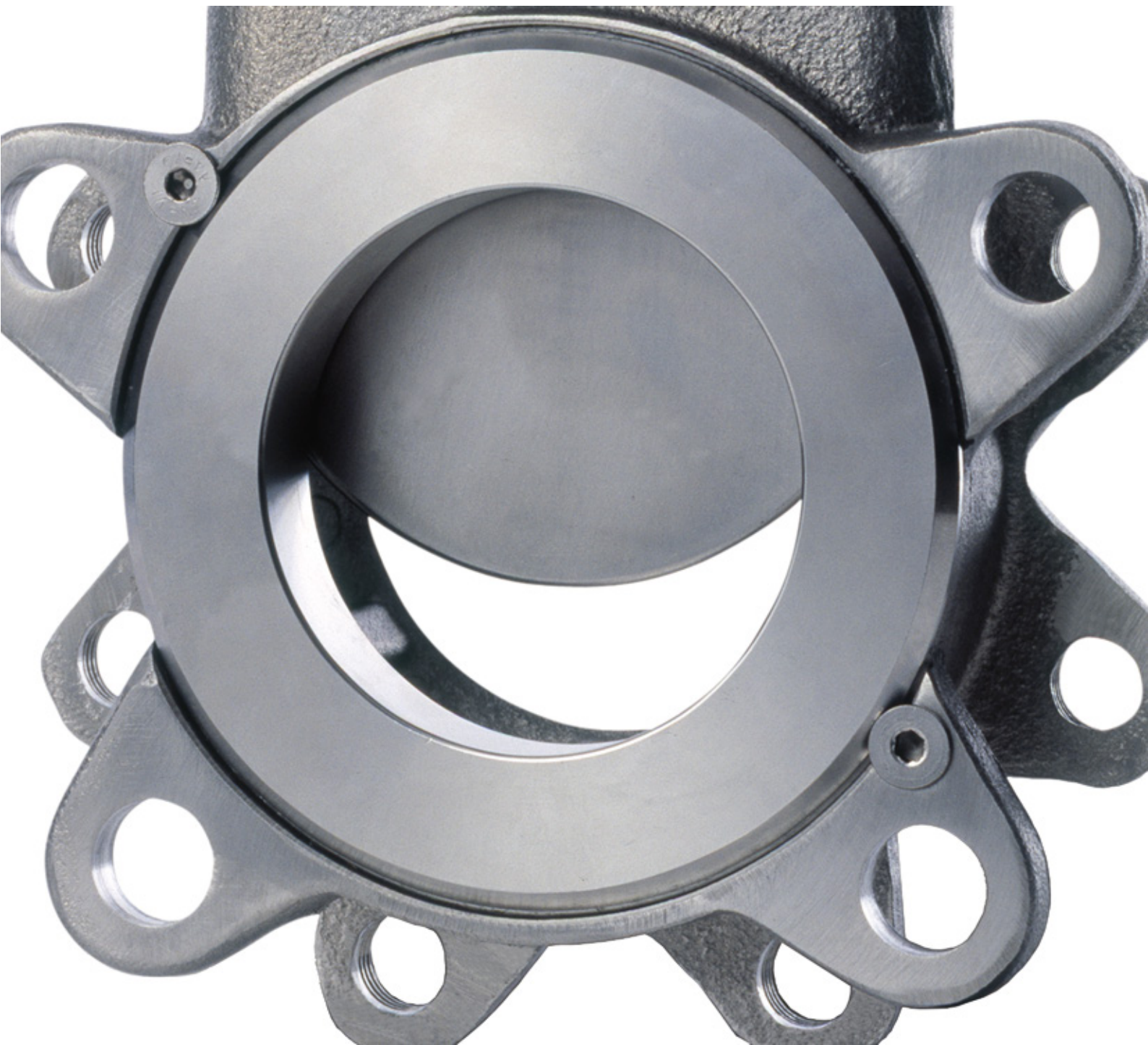

## Knife gate valve TV

Stafsjö's knife gate valve TV can be used as an isolation valve for a transmitter or sensor on a tank for which a short face-to-face length is required. The unique flange drilling and actuator makes it possible to mount it directly on the tank and the transmitter can be dismounted without draining the tank. The ratchet wrench enables fast and easy operation of the valve in spite of the wall installation.

TV has a valve body, gate and retainer ring in stainless steel. The retainer ring system offers several seat materials and very cost-efficient maintenance. As standard the TV valve is equipped with Stafsjö's unique gland box packing, TwinPack™, to secure that no media reaches surrounding environment. The top work consists of aluminium beams and stainless steel tie rods, which gives good corrosion resistance and a stable operation. As standard it comes with a ratchet wrench in stainless steel.

The TV valve is designed, manufactured, inspected and tested according to the European Pressure Equipment Directive (PED 97/23/EC) category I and II module A1. The valve is CE marked when it is applicable.



### Proven and reliable shut-off

The gate and valve body design, especially the bore, gives the valve its ability to securely and effectively shut-off almost any flow. Minimal friction makes the valve easy to operate.

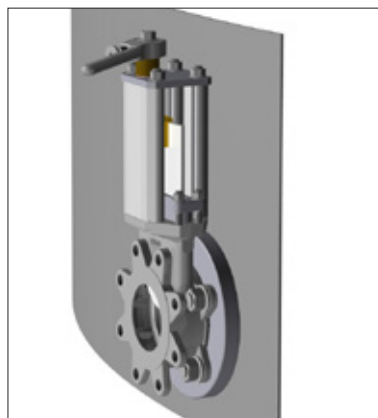

### Unique flange drilling enables end-of-pipe installations

The TV valve is possible to mount directly on the tank without any counter-flange and the ratchet wrench enables fast and easy operation of the valve.



### Excellent adaptability

TV can easily be customized. The retainer ring system offers flexibility and cost-efficient on-site maintenance.

## Design data

Sizes	Flange drilling	Face-to-face dimension	ATEX design
DN 80	EN 1092 PN 10- Stafsjö standard ASME/ANSI B16.5 Class 150- Stafsjö standard ASME/ANSI B16.5 Class 150- ASME/ANSI B16.5 Class 150	Stafsjö manufacturing standard MSS SP-81 TAPPI TIS 405-8	ATEX 94/ 9/EC II cat 3 G/D for zone 2 and 22 on request
Leakage rate		Pressure tests	
EN 12266-1:2012 rate A: No visually detectable leakage is allowed for duration of the test.		Pressure tests are performed with water at 20° C according to EN 12266-1:2012. Pressure shell test: 1,5 times maximum allowable working pressure for open valve. Pressure seat tightness test: 1,1 times maximum allowable differential pressure for closed valve.	
Maximum working pressure body at 20°C		Maximum differential pressure at 20°C	
DN	bar	DN	bar
80	16	80	3,5

## Basic equipment

A. Valve Body			
Material	Code	Type	Maximum temperature °C
Stainless steel	(E)	EN 1.4408	400
B. Gate			
Material	Type		
Stainless steel	EN 1.4404/AISI 316L		
C. Retainer ring			
Material	Type		
Stainless steel	EN 1.4408		
D. Seat			
Material	Code	Maximum temperature °C	
EPDM	(E)	120	
Nitrile	(N)	100	
Viton	(V)	180	
PTFE with o-ring Nitrile	(P)	100	
PTFE with o-ring Viton	(PV)	180	
E. Box Packing			
Material	Code	Maximum temperature °C	
TwinPack™	(TY)	260	
PTFE	(TF)	280	

## Actuators

Manual	
Ratchet wrench <sup>2)</sup>	(RW)

# Specify the Stafsjö valve

Stafsjö's valves are modular designed and they can easily be customized with gate, seat and box packings and accessories according to media and requirements. Below are examples of how you can specify your Stafsjö valve. Further information is available on [www.stafsjo.com](http://www.stafsjo.com).

**TV-E-200-P-TY-RW-PN10**

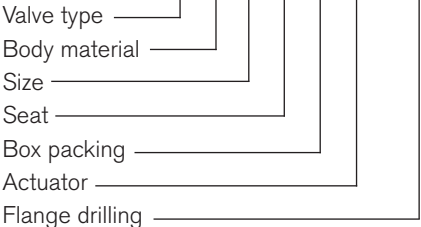

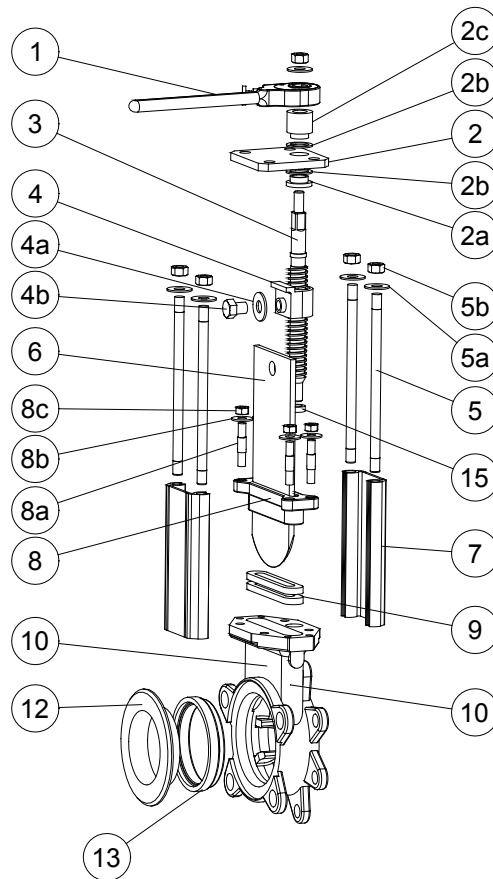

## Part list

Pos.	Part	Material (Name)
1	Ratchet wrench	Stainless steel (EN 1.4408)
2	Yoke	Stainless steel (EN 1.4301)
2a	Bearing	Brass (CuZn39Pb3)
2b	Bearing washer	POM
2c	Bearing	Brass (CuZn39Pb3)
3	Stem	Stainless steel (EN 1.4016)
4	Stem nut	Brass (CW603N)
4a	Washer	Stainless steel A2
4b	Screw	Stainless steel A2
5	Tie rod	Stainless steel (EN 1.4301)
5a	Washer	Stainless steel (A2)
5b	Nut	Stainless steel (A2)

Pos.	Part	Material (Name)
6	Gate	See equipment B
7	Beam	Aluminium (EN AW-6063-T6)
8	Gland	Stainless steel (EN 1.4408)
8a	Stud bolt	Stainless steel (A2), zinc coated
8b	Washer	A2
8c	Nut	Stainless steel (A2), zinc coated
9 <sup>1)</sup>	Box packing	See equipment E
10	Valve body	See equipment A
12	Retianer ring	See equipment C
13 <sup>1)</sup>	Seat	See equipment D
15	Bushing	Oil-bronze

<sup>1)</sup> Recommended spare parts

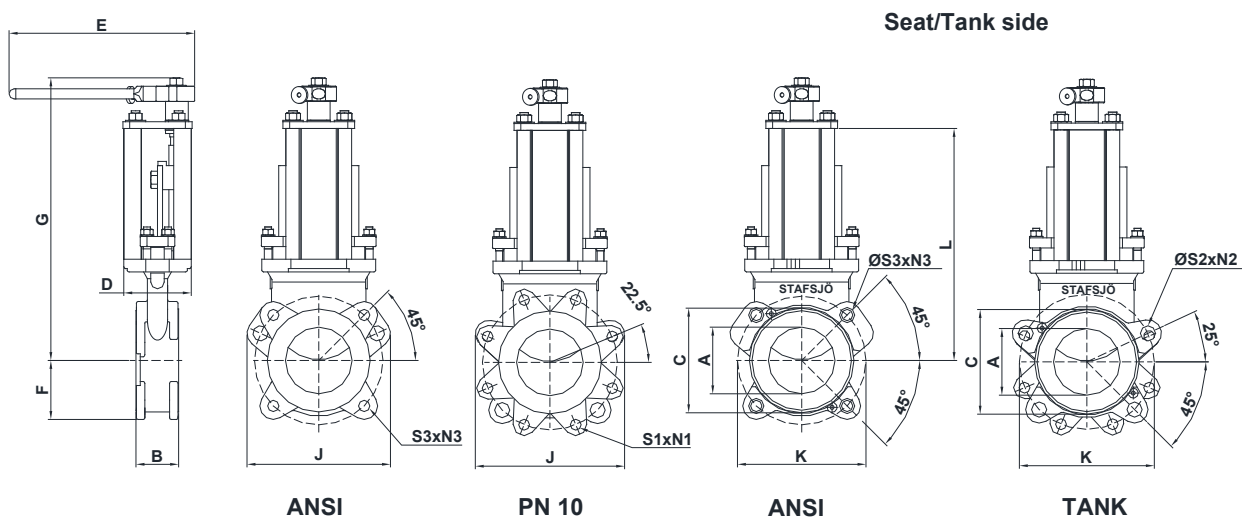

## Main dimensions

Dimensions (mm)																
Flange drilling	A	B	C	D	E	F	G	J	K	L	S1	N1	S2	N2	S3	N3
PN 10	79	51	124	80	220	88	335	177	160	275	M16	8	18	4	-	-
ASME/ANSI B16.5 Class 150	79	51	124	80	220	70	335	170	152	275	-	-	18	4	5/8-11	4
															UNC	

### Weight valve with ratchet wrench

DN	80
kg	8

Main dimensions are only for information. Contact Stafsjo for certified drawings.

Архангельск (8182)63-90-72  
 Астана (7172)727-132  
 Астрахань (8512)99-46-04  
 Барнаул (3852)73-04-60  
 Белгород (4722)40-23-64  
 Брянск (4832)59-03-52  
 Владивосток (423)249-28-31  
 Волгоград (844)278-03-48  
 Вологда (8172)26-41-59  
 Воронеж (473)204-51-73  
 Екатеринбург (343)384-55-89  
 Иваново (4932)77-34-06

Ижевск (3412)26-03-58  
 Иркутск (395)279-98-46  
 Казань (843)206-01-48  
 Калининград (4012)72-03-81  
 Калуга (4842)92-23-67  
 Кемерово (3842)65-04-62  
 Киров (8332)68-02-04  
 Краснодар (861)203-40-90  
 Красноярск (391)204-63-61  
 Курск (4712)77-13-04  
 Липецк (4742)52-20-81  
 Киргизия (996)312-96-26-47

Магнитогорск (3519)55-03-13  
 Москва (495)268-04-70  
 Мурманск (8152)59-64-93  
 Набережные Челны (8552)20-53-41  
 Нижний Новгород (831)429-08-12  
 Новокузнецк (3843)20-46-81  
 Новосибирск (383)227-86-73  
 Омск (3812)21-46-40  
 Орел (4862)44-53-42  
 Оренбург (3532)37-68-04  
 Пенза (8412)22-31-16  
 Казахстан (772)734-952-31

Пермь (342)205-81-47  
 Ростов-на-Дону (863)308-18-15  
 Рязань (4912)46-61-64  
 Самара (846)206-03-16  
 Санкт-Петербург (812)309-46-40  
 Саратов (845)249-38-78  
 Севастополь (8692)22-31-93  
 Симферополь (3652)67-13-56  
 Смоленск (4812)29-41-54  
 Сочи (862)225-72-31  
 Ставрополь (8652)20-65-13  
 Россия (495)268-04-70

Сургут (3462)77-98-35  
 Тверь (4822)63-31-35  
 Томск (3822)98-41-53  
 Тула (4872)74-02-29  
 Тюмень (3452)66-21-18  
 Ульяновск (8422)24-23-59  
 Уфа (347)229-48-12  
 Хабаровск (4212)92-98-04  
 Челябинск (351)202-03-61  
 Череповец (8202)49-02-64  
 Ярославль (4852)69-52-93